



CAIET SCHEME ΔΠΡΕΞ ΕΤΜ 100

uz intern

1986

REV	DESCRIPTION	DATE	APPROVAL
A	ERN N 2514		
B	ECN N 2682-2		
C	ECN N 2767-2		

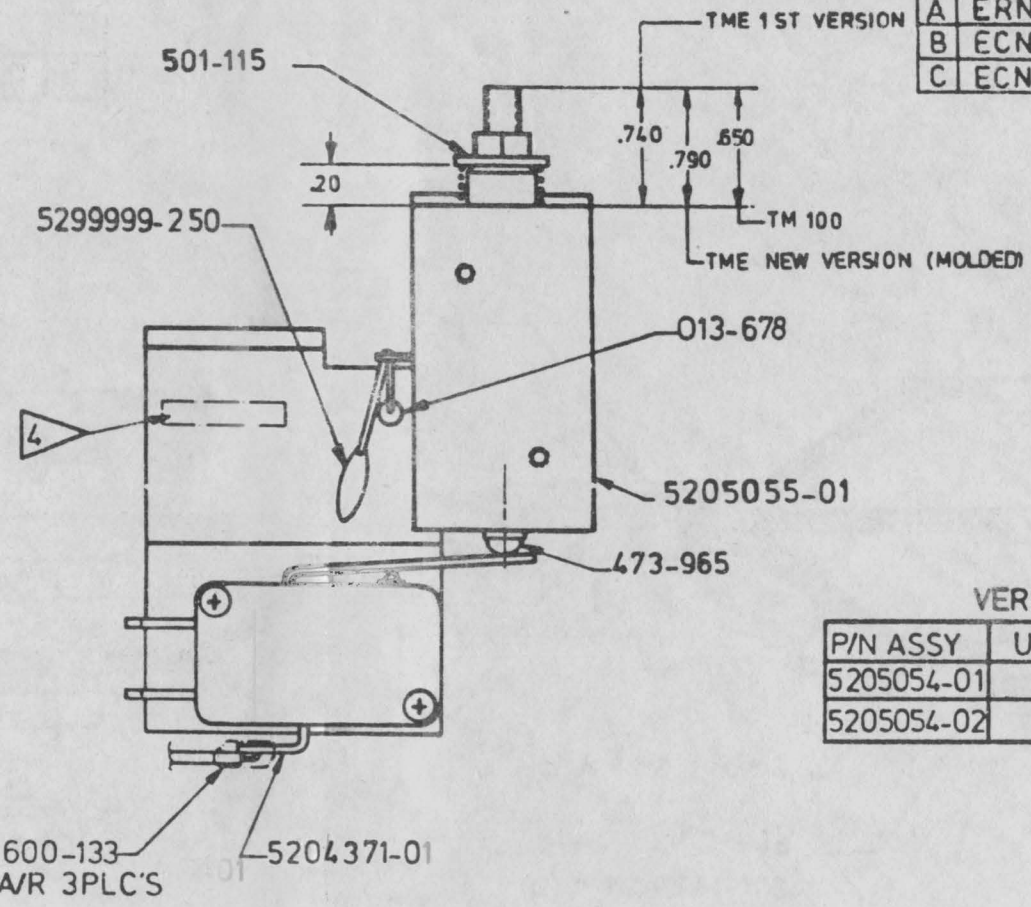
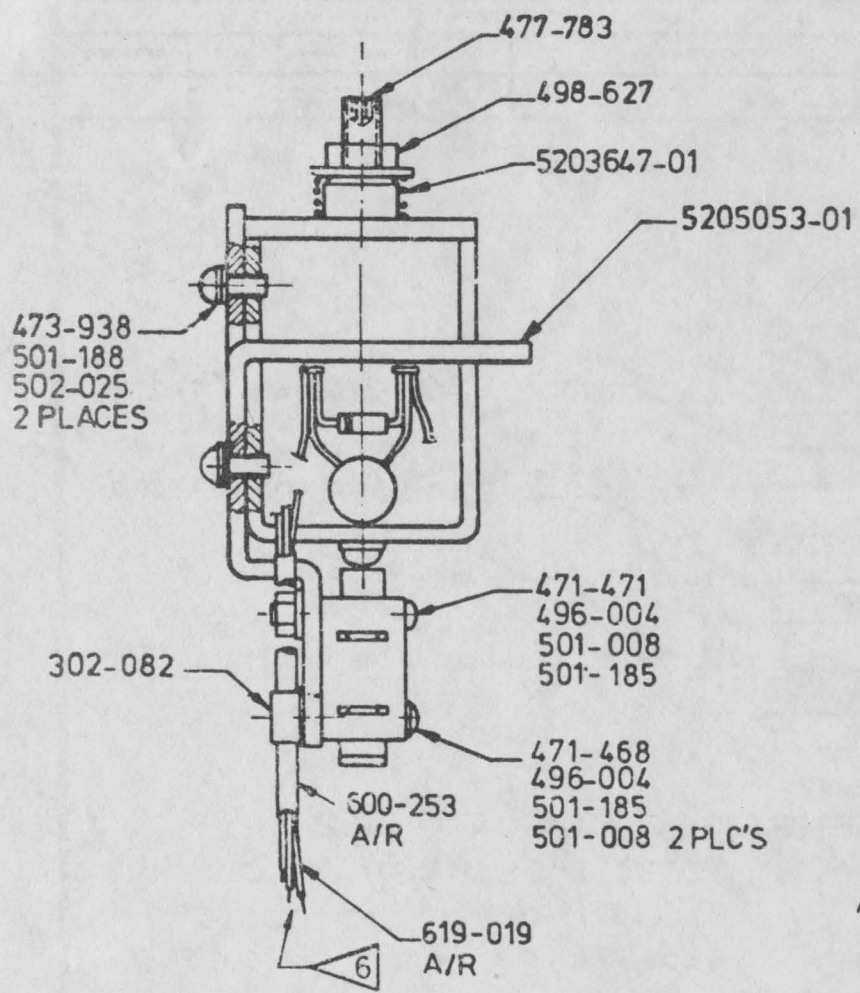

VERSION TABLE

P/N ASSY	USED ON	CONNEX BODY	PIN
5205054-01	TM 100	166-059 (P5)	187-030
5205054-02	TME	167-450 (BP5)	167-671

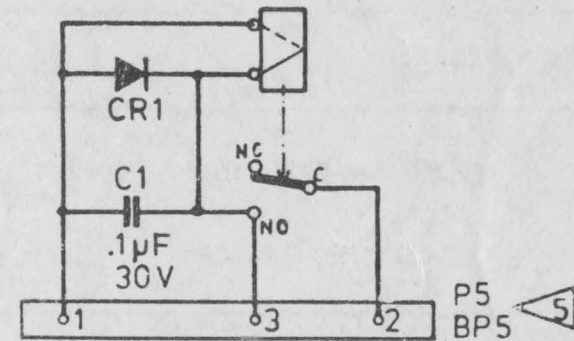

SCHMATIC

- 5 CONNECTOR PINS AND BODIES NOT SHOWN FOR CLARITY.
 - 5 MARK ASSY NO PER VERSION TABLE
 - 4 MARK ASSY NO PER AMPEX STD BD 1-1
 - 3. HEAVY LINE ON DIODE INDICATES CATHODE
 - 2. ASSEMBLE PER AMPEX STD HC2-2
 - 1. ASSY NO TO BE AS PER VERSION TABLE
- NOTES

DO NOT SCALE DRAWING UNLESS OTHERWISE SPECIFIED		AMPEX	
5205054		FILE PROTECT ASSY	
TM100-TME		C 5205052	
		1 OF 1	

REVISIONS				
ISSUE	DESCRIPTION	DATE	DRAFTSMAN	APPROVAL
D	N2388	21/1/78	H. WASE	

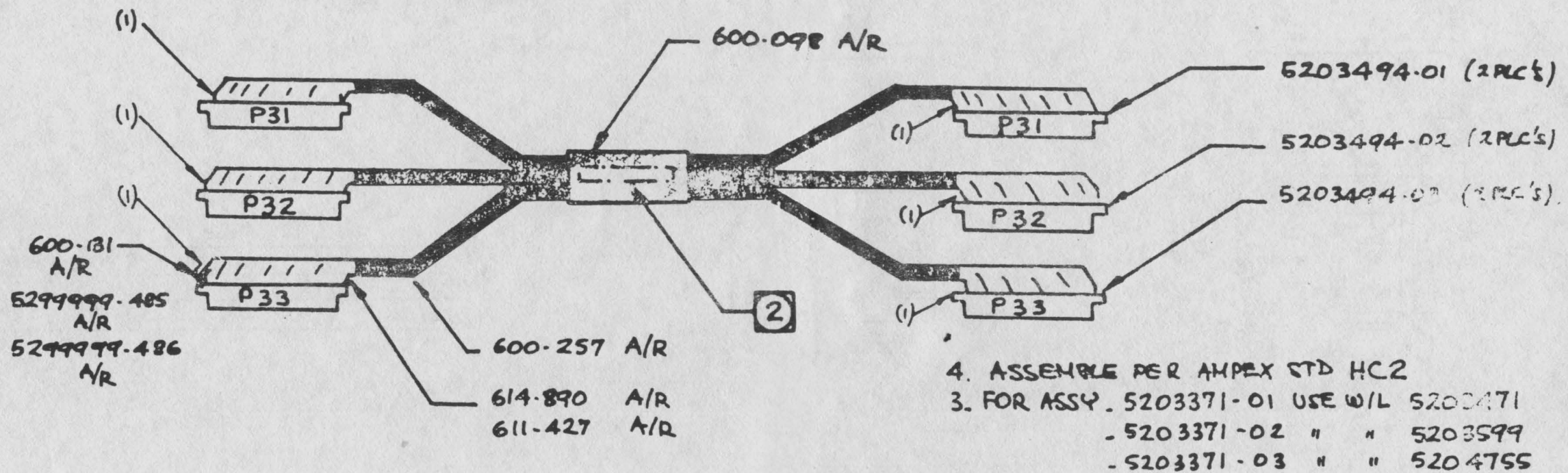

- 4. ASSEMBLE PER AMPEX STD HC2
- 3. FOR ASSY. 5203371-01 USE W/L 5200471
 - 5203371-02 " " 5203599
 - 5203371-03 " " 5204755

② MARK P/N DASH & ISSUE LETTER AS PER AMPEX SPEC 3124500

NOTES: 1. FOR B/M SEE 5203371

5203300	TM100
FAL	
NEXT ASSY.	1ST USED ON
APPLICATION	

DO NOT SCALE DRAWING
 UNLESS OTHERWISE SPECIFIED
 DIMENSIONS ARE IN INCHES.
 DECIMALS TOLERANCES ANGLES
 XX ± / XXX ± / ° ±
 BREAK ALL SHARP EDGES APPROX 0.10 C/BORE
 AND SPOTFACE CORNER RADI APPROX 0.10
 ROUGHNESS OF ALL MACHINED
 SURFACES PER MIL-STD-10 ✓
 MATERIAL
 FINISH

DWG NO 5203371
 THE INFORMATION HEREON IS THE PROPERTY OF
 AMPEX COMPUTER PRODUCTS DIVISION NO RE-
 PRODUCTION OR UNAUTHORIZED USE IN PART OR
 IN WHOLE SHALL BE MADE WITHOUT WRITTEN
 CONSENT OF AMPEX CORPORATION
 PROJ ENGR
 ENGR
 CHKR P.J. ... 21/1/78
 DFTSMN U. ...
 MODEL
 T M X STACK [] []
 VIDEO [] AUDIO [] PROF []
 INSTRU [] [] CONS []

AMPEX SA. NIVELLES BELGIUM

TITLE
CABLE DAISSY CHAIN
SET OF CABLE

BM NO BM []
 ON DWG [] SEPARATE
 REF DWG [] []

SIZE **A** DWG NO **5203371** ISSUE **A**
 SCALE - SHEET 1 OF 1

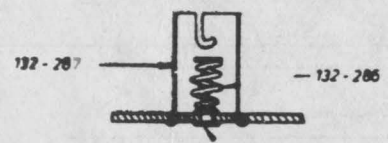

SECTION 'A-A'
6 PLACES

REV	DESCRIPTION	DATE	BY	CHKD
A	ERN N 1302	11-24-50	MM	
B	ECH N 1742	1-7-51	MM	
C	ECH N 1763	2-27-51	MM	
D	ECH N 1938	4-18-51	MM	
E	ECH N 2106	10-16-51	MM	
F	ECH N 2485	1-20-52	MM	
G	ECH N 2469	2-28-52	MM	
H	ECH N 2601/3	11-7-52	MM	

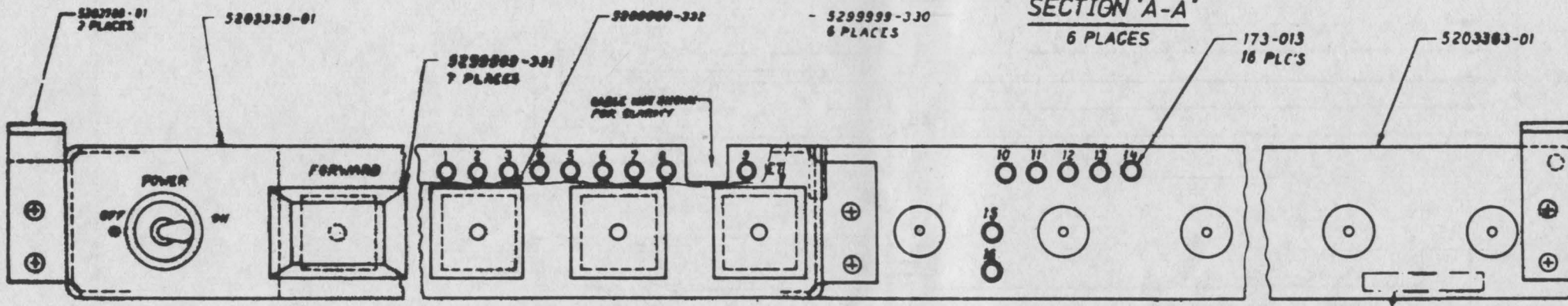

VERSION TABLE 2

ASSY NO.	PART A	PART B
5203380-01	5203386-01	NONE
5203380-02	NONE	5203386-02

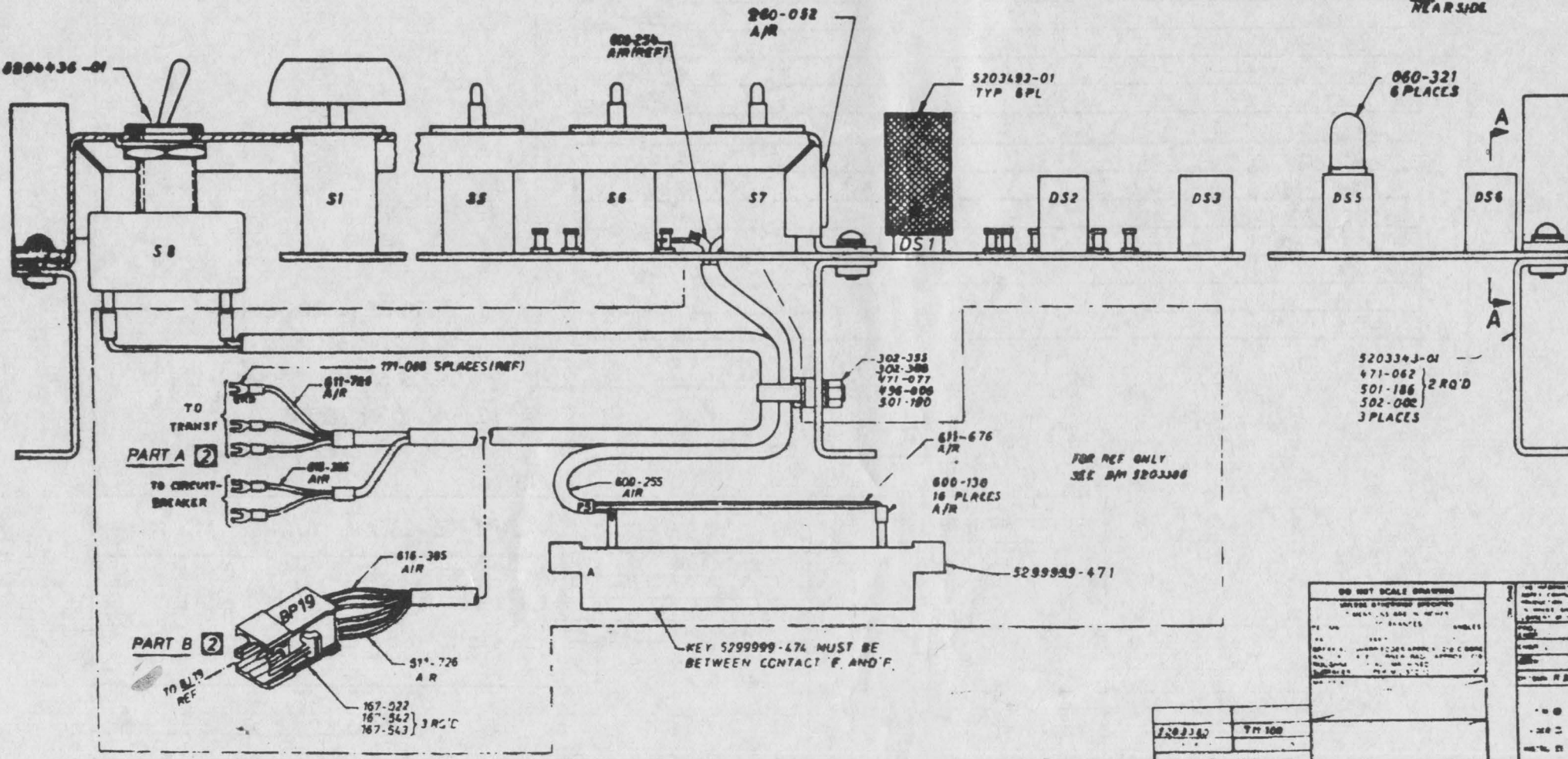

- NOTES
- IDENTIFY PER AMPLEX SPEC 3124500, PARA 3 RUBBER STAMP PERMISSIBLE
 - SWAGE POST P/N 132-288 PRIOR INSTALLATION OF SPRING P/N 132-286 AND SHELL 132-287
 - FOR REF. WIRE LIST NO. IS 5203385
 - PART NO. TO BE AS PER VERSION TABLE 1. FOR SCHEMATIC SEE 5203381

DO NOT SCALE DRAWING

AMPEX

OPERATOR CONTROL PANEL ASSEMBLY

5203382

1 OF 1

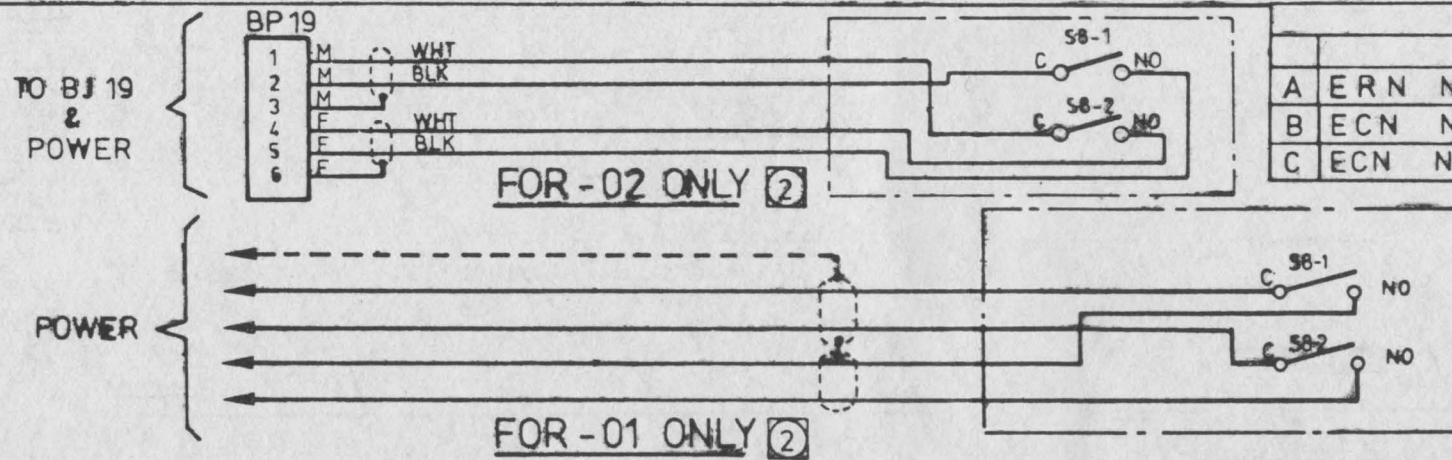

REVISIONS			
REV	DESCRIPTION	DATE	BY
A	ERN N 1302	10/3/73	H. Mayer
B	ECN N 1938	1.12.74	H. G.
C	ECN N 2455	10/11/77	H.G.

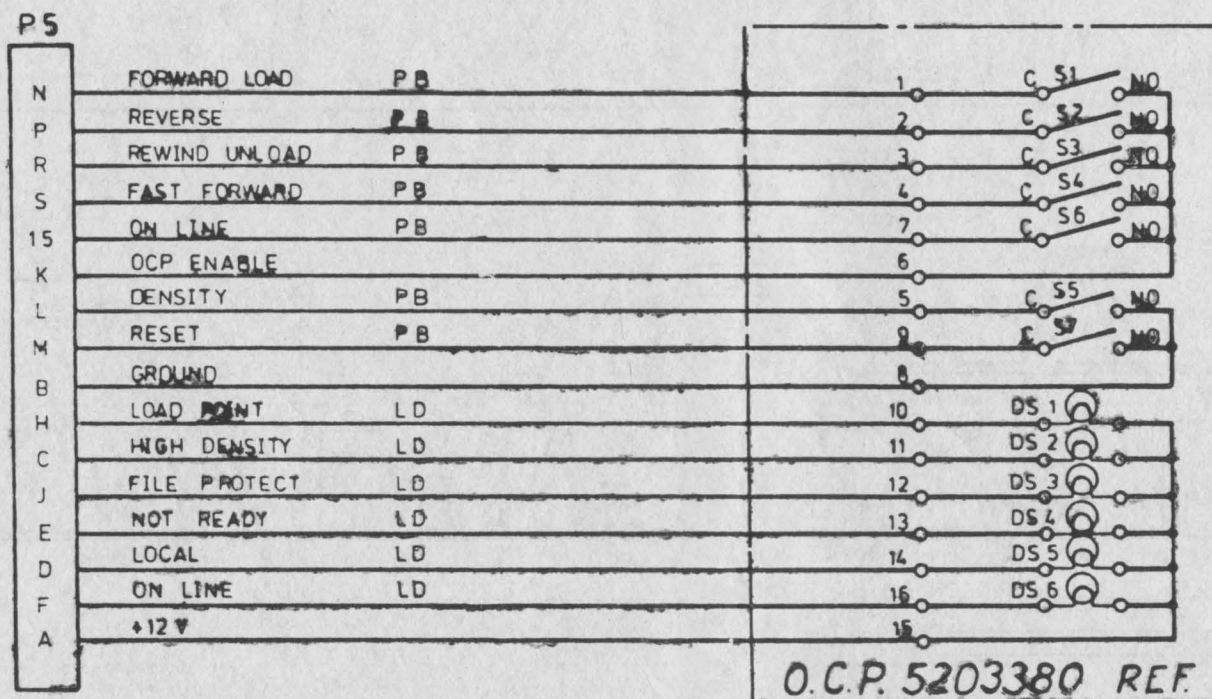

O.C.P. 5203380 REF.

- 3. S8 TO BE 4620190 01
- S5 TO BE 5299999-332
- S1,2,3,4,6,7 ARE 5299999-300.
- ② P/N TO BE 5203380-XX.
- 1. FOR REF DWG SEE 5203382.

NOTES:

DO NOT SCALE DRAWING		AMPEX SA NIVELLES BELGIUM	
5203380		LEMINEUR QUINET MARRONE MAEGERMAN	OPERATOR CONTROL PANEL SCHEMATIC
T.M. 100		B	5203381 C
		NONE	10F 1

REVISIONS					
ISSUE	DESCRIPTION	DATE	DRAFTSMAN	DATE	APPROVAL
R	ECN N2731-5		H G		

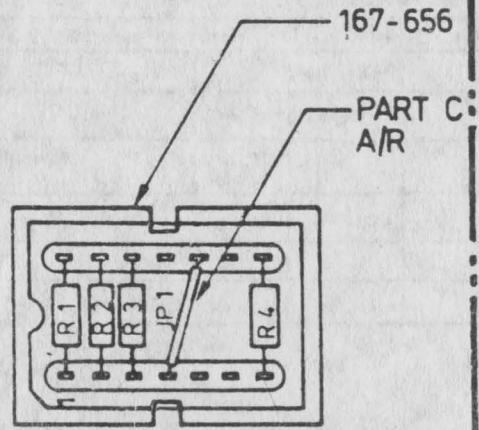

FOR ALL DASHES EXCEPT -05.

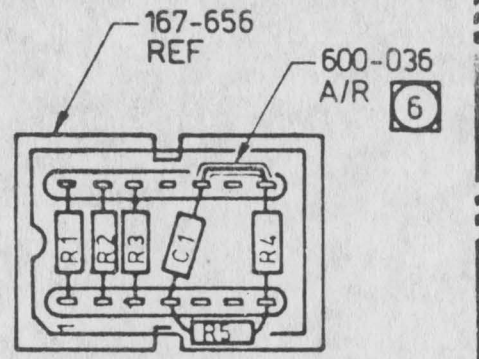

FOR -05 ONLY.

VERSION TABLE ③

	PART NUMBER	FUNC IPS	COMPONENTS					
			PART A	PART B	PT. C	PART D	PART E	PART F
CEM MOTOR	5203541-02	45	049-617	049-868	614-762	049-529	---	---
	↑ -12	37,5	↑ -868	↑ -603	↑	↑	---	---
	-22	25	↑ -870	↑ -662	↑	↑	---	---
	-32	12,5	↑ -874	↑ -874	↑	↓	---	---
	-42	18,75	↑ -872	↑ -873	↑	049-529	---	---
PE/NRZ EC MOTOR	-03	45	↑ -617	↑ -618	↑	049-613	---	---
	-13	37,5	↑ -868	↑ -869	↑	↑	---	---
	-23	25	↑ -870	↑ -871	↓	↑	---	---
	-43	18,75	↑ -872	↑ -873	614-762	↑	---	---
	-04	45	↑ -617	↑ -618	---	↑	---	---
	-14	37,5	↑ -868	↑ -869	---	↑	---	---
	-24	25	↑ -870	↑ -871	---	↑	---	---
	-44	18,75	↑ -872	↑ -873	---	↑	---	---
	-33	12,5	↑ -874	↑ -721	614-762	↑	---	---
	-34	12,5	↑ -874	↑ -721	---	↑	---	---
↓ -54	50	↓ -866	↓ -868	---	↓	---	---	
	5203541-05	45	049-617	049-868	---	049-613	035-883	5299997-432

P/N	REF. DES	③
PART A	R2	③
PART B	R1,R3	③
PART C	JP1	③
PART D	R4	③
PART E	C1	③
PART F	R5	③

- ⑥ AXIAL LEAD WIRE FROM C1 TO BE INSULATED.
- 5. IDENTIFY PER AMPEX STD BD1-1.
- 4. FOR SCHEMATIC SEE 5203542.
- ③ P/N TO BE AS PER VERSION TABLE.
- 2. COMPONENT DESIGNATIONS ARE FOR REF. ONLY.
- 1. ASSEMBLE PER AMPEX STD HC2-2.

NOTES:

5203541	TM 100
---------	--------

DO NOT SCALE DRAWING
UNLESS OTHERWISE SPECIFIED

5203543

AMPEX S.A. NIVELLES BELGIUM

PCBA OPTION
SERVO SINGLE SPEED

③ 5203543 R

NONE 1 OF 1

REVISIONS					
INS.	DESCRIPTION	DATE	DRAFTSMAN	DATE	APPROVAL
J	ECN N 2058	9-X-74	H.G.		
K	ECN N 2061	11-X-74	H.G.		
L	ECN N 2186	7-11-75	H.P.		
M	ECN N 2455	14 DEC 77	H.G.		
N	ECN N 2487	4-14-78	M.BE		
P	ECN N 2731-4	20 OCT 78	H.E.		

VERSION TABLE ①

	PART NUMBER	FUNCTION	COMP. DESIGNATION					
			R2	R1,R3	PT. A	R4	C1	R5
CEM MOTOR	5203541-02	45 IPS	33K	43K	JP1	5.1K	—	—
	↑ -12	37.5 IPS	43K	51K	↑	↑	—	—
	-22	25 IPS	75K	82K	↑	↑	—	—
	-32	12.5 IPS	180K	180K	↑	↓	—	—
	-42	18.75 IPS	110K	130K	↑	5.1K	—	—
EC MOTOR	-03	45 IPS	33K	47K	↑	15K	—	—
	-13	37.5 IPS	43K	56K	↑	↑	—	—
	-23	25 IPS	75K	91K	↓	↑	—	—
	-43	18.75 IPS	110K	130K	JP1	↑	—	—
	-04	45 IPS	33K	47K	—	↑	—	—
	-14	37.5 IPS	43K	56K	—	↑	—	—
	-24	25 IPS	75K	91K	—	↑	—	—
	-44	18.75 IPS	110K	130K	—	↓	—	—
	-33	12.5 IPS	180K	200K	JP1	15K	—	—
	-34	12.5 IPS	180K	200K	—	15K	—	—
↓	-54	50 IPS	30K	43K	—	15K	—	—
	5203541-05	45 IPS	33K	43K	—	15K	.068μF	4.3K

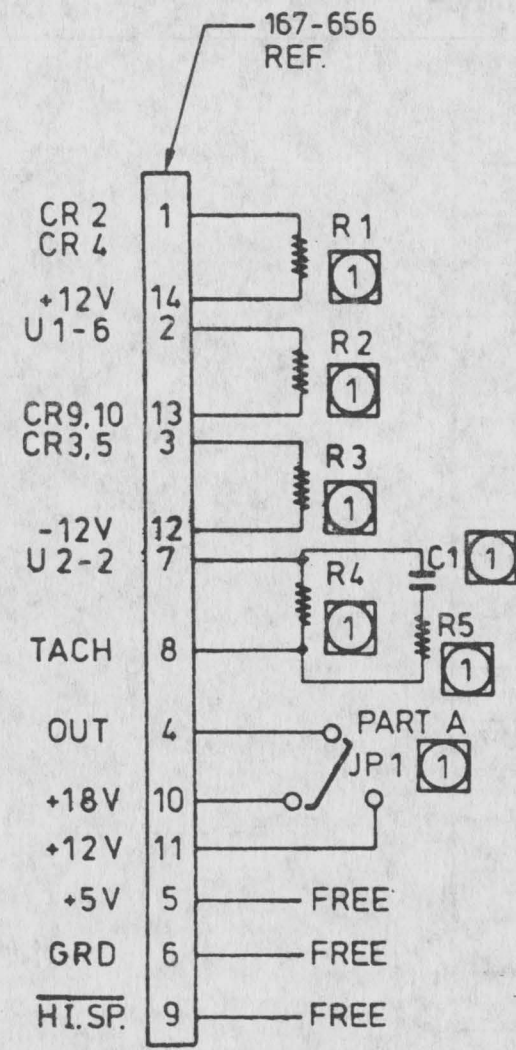

- 3. ALL CAPACITOR VALUES ARE IN MICROFARADS, 50V, 5%.
- 2. ALL RESISTOR VALUES ARE IN OHMS, 1/8W, ±5%.
- ① SEE VERSION TABLE.

NOTES:

DO NOT SCALE DRAWING UNLESS OTHERWISE SPECIFIED		AMPEX SA NIVELLES BELGIUM	
5203542		SCHEMATIC OPTION	
5203541 TM 100		SERVO SINGLE SPEED	
		B 5203542 P	
		1 OF 1	

PROTO
 ELEC. N. 2455
 CECNN2757-8

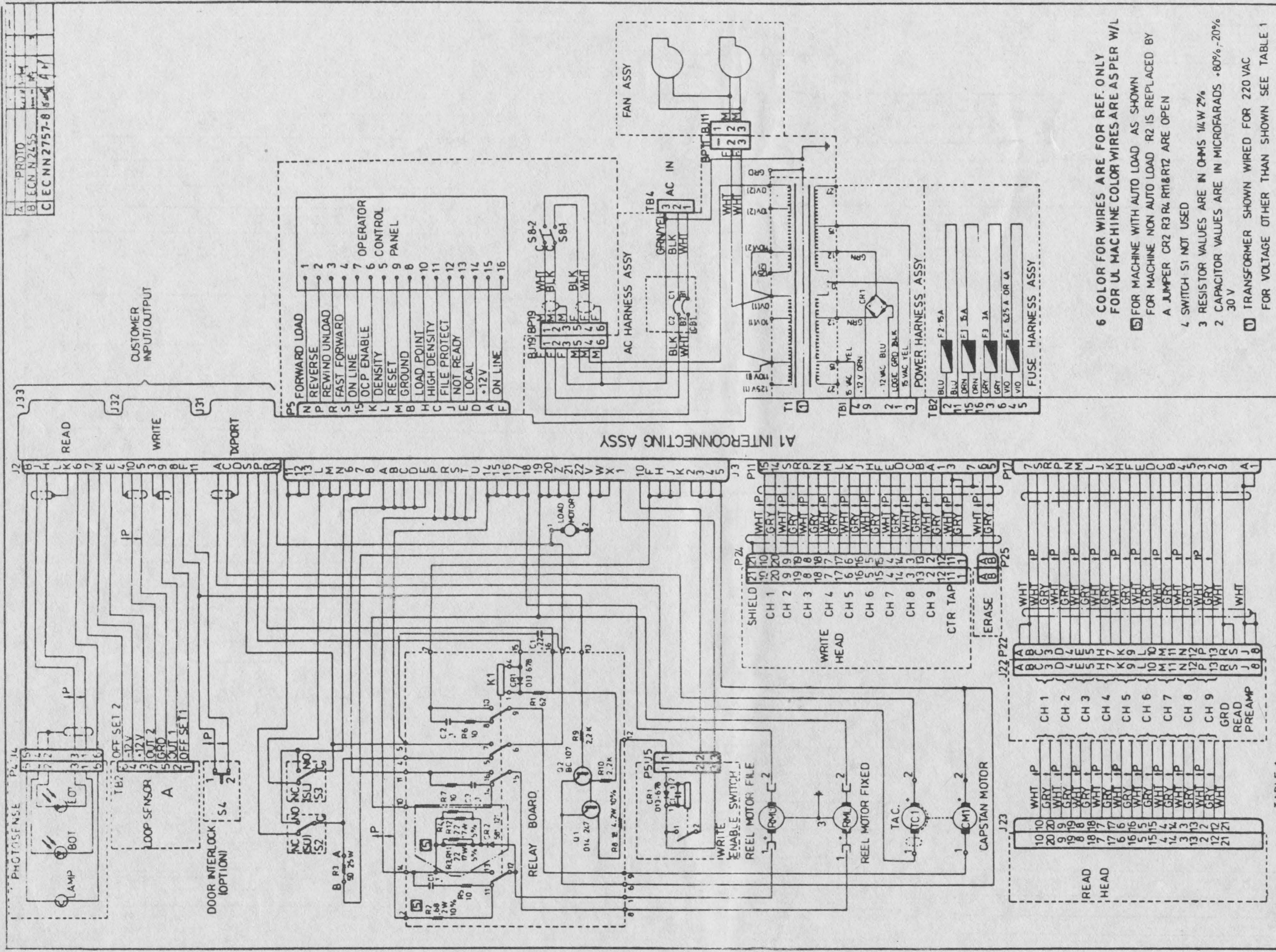

- 6 COLOR FOR WIRES ARE FOR REF. ONLY
 FOR UL MACHINE COLOR WIRES ARE AS PER W/L
- 5 FOR MACHINE WITH AUTO LOAD AS SHOWN
 FOR MACHINE NON AUTO LOAD R2 IS REPLACED BY
 A JUMPER CR2 R3 R4 R11 & R12 ARE OPEN
- 4 SWITCH S1 NOT USED
- 3 RESISTOR VALUES ARE IN OHMS 1/4W 2%
- 2 CAPACITOR VALUES ARE IN MICROFARADS +80% -20%
 30V
- 1 TRANSFORMER SHOWN WIRED FOR 220 VAC
 FOR VOLTAGE OTHER THAN SHOWN SEE TABLE 1

NOTES:

USE THIS SCHEMATIC WITH TXFMR 5203488

TABLE 1

INPUT VOLT	FROM	TO	FROM	TO	FROM	TO
100 VAC	T1-012	B19-4	1012	T011	M011	11012
110	T1-012	B19-4	1012	O111	M011	11012
115	T1-012	B19-4	1012	O111	M011	11012
125	T1-012	B19-4	1012	O111	M011	11012
200	T1-012	B19-4	1012	O111	M011	11012
210	T1-012	B19-4	1012	O111	M011	11012
215	T1-012	B19-4	1012	O111	M011	11012
220	T1-012	B19-4	1012	O111	M011	11012
225	T1-012	B19-4	1012	O111	M011	11012
230	T1-012	B19-4	1012	O111	M011	11012
235	T1-012	B19-4	1012	O111	M011	11012
240	T1-012	B19-4	1012	O111	M011	11012
250 VAC	T1-012	B19-4	1012	O111	M011	11012

AMPEX

SYSTEM SCHEMATIC

TM 100 +

5203488

5204518

1012

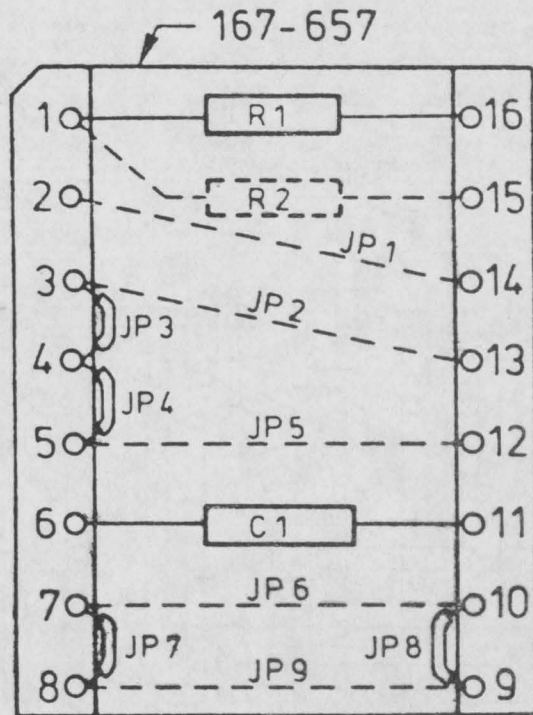

VERSION TABLE

PART NUMBER	JUMPER JP									R1	R2	C1
	1	2	3	4	5	6	7	8	9			
5203597 - 01			X	X			X	X		X	JP	X
- 02		X			X		X	X		X	JP	X
- 07	X		X	X	X				X	X	JP	X
- 09			X	X	X	X				X	-	X
- 10	X	X			X	X			X	X	JP	X
- 11					X		X	X		X	JP	X

REVISIONS					
ISSUE	DESCRIPTION	DATE	DRAFTSMAN	DATE	APPROVAL
B	ECN N 2487	4 APR 78	M.B.E		
C	ECN N 2719-2	10 OCT 78	HS		

CONVENIENCE TABLE

FUNCTION		JUMPER JP								
		1	2	3	4	5	6	7	8	9
RUN/STOP FWD/REV	OR	-					-	X	X	-
FWD/STOP REV/STOP		X					X	-	-	X
OFF-LINE INPUT	YES				-	X				
	NO				X	-				
FAST FWD (DDS) INPUT	YES		X	-						
	NO		-	X						

COMPONENT TABLE

PART NO.	REF. DESIGNATION	QTY
615 - 004	JP1 THRU JP9	A/R
049 - 613	R1	1
615 - 004	R2	A/R
034 - 240	C1	1

5. COMPONENT P/N ARE FOR REF. ONLY.
4. C1 CAPACITOR VALUE TO BE 220pF, 5%, 500V.
3. R1 RESISTOR VALUE TO BE 15KOHMS, 1/8W, 5%.
2. IDENTIFY PER AMPEX STD BD1-1.
1. PART NO. TO BE AS PER VERSION TABLE.

NOTES:

DO NOT SCALE DRAWING		UNLESS OTHERWISE SPECIFIED		DIMENSIONS ARE IN INCHES		DECIMALS - TOLERANCES - ANGLES		5203598		AMPEX SA NIVELLES BELGIUM	
BREAK ALL SHARP EDGES AND POINTS TO CORNER AND SPOTFACE - POWER DRILL APPROX. 1/16" ROUNDERNESS OF ALL MECHANICAL SURFACES - PER W. 100		MATERIAL		FINISH		TYPICAL		A GREGOIRE		JUMPER SOCKET ASSY 16 PINS	
5203597		TM 100		SCALE NONE		1 OF 1		B		5203598	
										C	

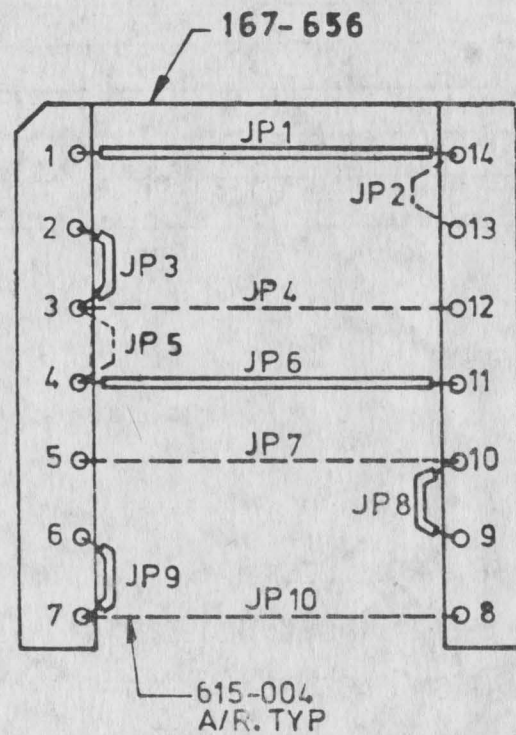

VERSION TABLE

PART NUMBER	JUMPER JP									
	1	2	3	4	5	6	7	8	9	10
5203595-01	X		X			X		X	X	
-02	X					X		X	X	
-03	X		X	X		X		X	X	
-06	X			X		X	X		X	
-07	X			X	X		X			X
-08	X				X		X			X
-09	X		X			X		X		X
5203595-05	X					X	X			X
5203595-04	X			X		X	X			X

REVISIONS					
SS.1	DESCRIPTION	DATE	DRAWN BY	DATE	APPROVAL
A	ERN N 1988	15-2-74			
C	ECN N 2455	14 DEC 77	KG		
D	ECN N 2487	4-IV-78	M.BE		

CONVENIENCE TABLE

FUNCTION		JUMPER JP									
		1	2	3	4	5	6	7	8	9	10
STATUS.WRITE ENABLE	OR									X	-
STATUS.FILE PROTECT										-	X
STATUS.HI DENS	OR						X	-			
STATUS.LO DENS							-	X			
READY STATUS	YES			-							
	NO		X								
SINGLE DENSITY	YES			X							
	NO			-							
FIRST OCP LAMP BOT	OR	X	-								
ON LINE AND SELECT		-	X								
BOT STATUS IN REVERSE	INDUSTRY				X	-					
	TM7				-	X					

2 IDENTIFY PER AMPEX STD BD1-1

1 PART NO. TO BE AS PER VERSION TABLE NOTES

DO NOT SCALE DRAWING UNLESS OTHERWISE SPECIFIED		5203596	AMPEX S.A. NIVELLES BELGIUM	
5203595 TM 100			JUMPER SOCKET ASSY 14 PINS	
		M. B. BE		15-2-74
		B		5203596
		NONE		1 OF 1

REVISIONS					
NO.	DESCRIPTION	DATE	DRAWN BY	DATE	APPROVAL
A	ERN N 1304				
B	ECN N 1945	1-11-74	M DE		
D	ECN N 2487	24-10-75	M. B E	27/11/75	TE
E	ECN N 2759	10/01/78	W B	10/01/78	C. CHAU

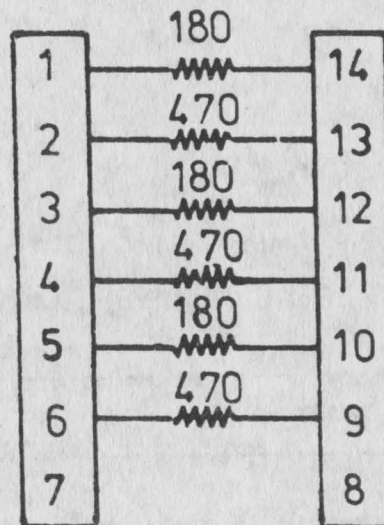
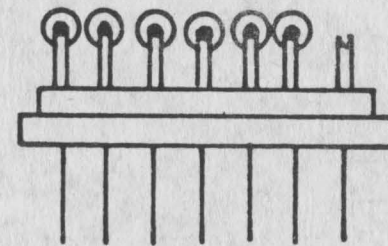
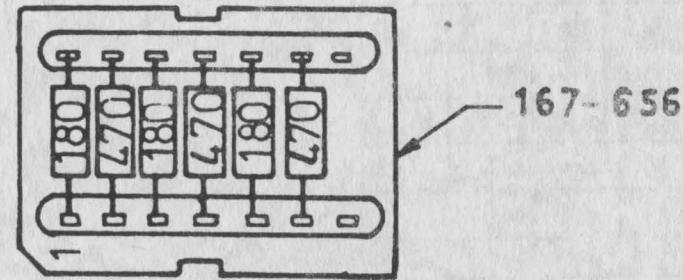

- ⑦ MAY BE PURCHASE FROM "BECKMAN RESISTOR NETWORK" TYPE 898-1 MODEL 5203575-01.
 (VENDOR: "REGULATION MESURE" AVENUE R. VANDENDRIESSCHE, 73 1150 BRUXELLES)
- 6 ALL RESISTOR VALUES ARE IN OHMS, 5%, 1/8 W.
5. P/N FOR RESISTOR OF 470 OHMS IS 041-624
4. P/N FOR RESISTOR OF 180 OHMS IS 049-758
3. P/N TO BE 5203575-01
2. MARK PART NUMBER PER BD1-1
1. ASSEMBLE PER AMPEX STD.

NOTES:

5203600	TM 100
NET ASSY	REF. ON
APPLICATION	

DO NOT SCALE DRAWING UNLESS OTHERWISE SPECIFIED DIMENSIONS ARE IN INCHES		AMPEX SA NIVELLES BELGIUM	
DE J.M.S. TOULOUSE		OPTION	
BREAK ALL SHARP EDGES APPROX 0.01 BORE AND SPOTFACE CORNER RAD APPROX 0.01 ROUGHNESS OF ALL MACHINED SURFACES PER MIL STD 12.5		TERMINATION RESISTOR	
MATERIAL		7	
5203600		5203575	
TM 100		E	
APPLICATION		SCALE 10:1	

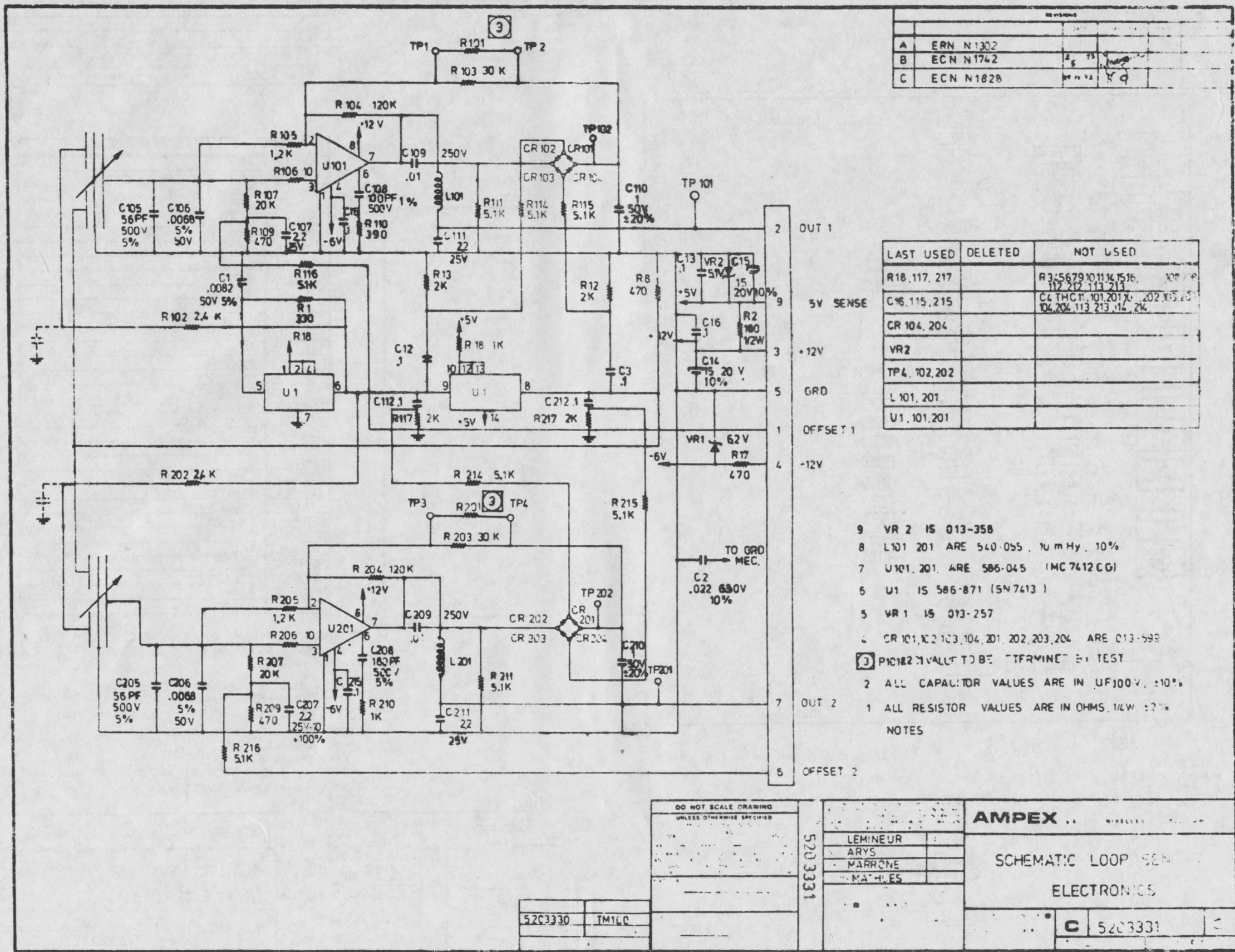

REV	DATE	BY	CHK
A	ERN N1302		
B	ECN N1742		
C	ECN N1828		

LAST USED	DELETED	NOT USED
R18, 117, 217		R3, 5679, 1011, 14, 15, 16, 102, 201, 112, 212, 113, 213
C16, 115, 215		C4, THCT, 101, 201, 102, 202, 105, 205, 104, 204, 113, 213, 114, 214
CR 104, 204		
VR2		
TP4, 102, 202		
L 101, 201		
U1, 101, 201		

- 9 VR 2 IS 013-358
 - 8 L101, 201 ARE 540-055, 10 mHy, 10%
 - 7 U101, 201 ARE 586-045 (MC7412 CG)
 - 6 U1 IS 586-871 (SN7413 I)
 - 5 VR 1 IS 013-257
 - 4 CR 101, 102, 103, 104, 201, 202, 203, 204 ARE 013-598
 - ③ PIC182 VALUE TO BE DETERMINED BY TEST
 - 2 ALL CAPACITOR VALUES ARE IN UF100V, ±10%
 - 1 ALL RESISTOR VALUES ARE IN OHMS, 1/W, ±2%
- NOTES

DO NOT SCALE DRAWING UNLESS OTHERWISE SPECIFIED		5203331	AMPEX	
			LEMINEUR	
			ARYS	
			MARRONE	
		MATHIES		SCHEMATIC LOOP SENSOR ELECTRONICS
5203330	TM100			C 5203331

REVISIONS				
REV	DESCRIPTION	DATE	DRAFTSMAN	APPROVAL
A	ERN N 1302	5/77	[Signature]	[Signature]
B	ECN N 1828	11/77	[Signature]	[Signature]
C	ECN N 2840-2	11/20/79	[Signature]	[Signature]

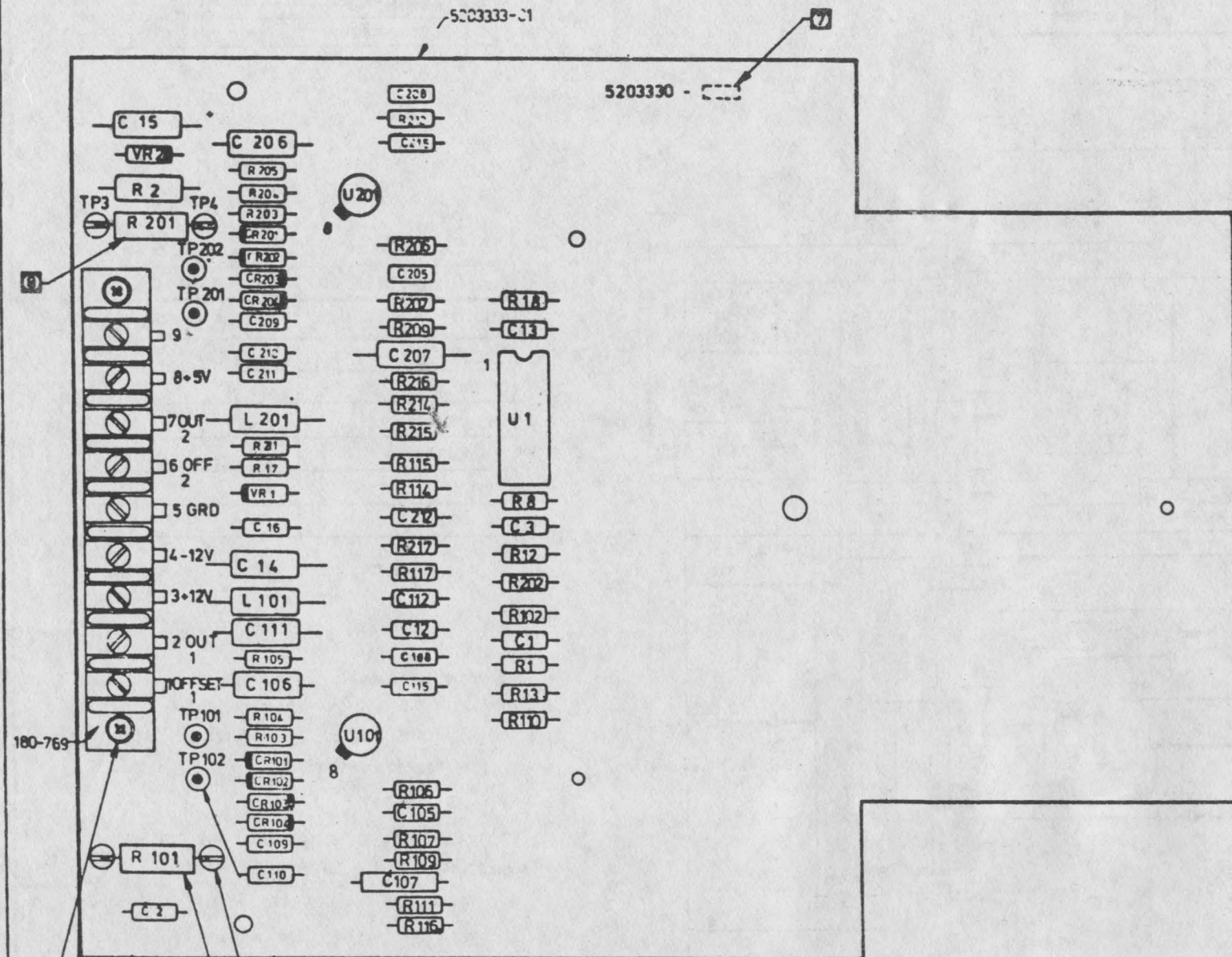

PART NO	REF DESIGNATION
013-257	VR 1
013-599	CR 101, 201, 102, 202, 103, 203, 104, 204
5299999-387	C107, 207, 111, 211
034-182	C105, 205
034-347	C208
5299999-362	C109, 209
035-846	C1
037-985	C14, 15
5299997-102	R10, 210
-303	R103, 203
-331	R1
-471	R8, 17, 109, 209
-122	R105, 205
-124	R104, 204
-100	R106, 206
-203	R107, 207
-202	R12, 13, 117, 217
5299997-512	R111, 211, 114, 214, 115, 215, 116, 216
173-012	TP 101, 201, 102, 202
540-055	L101, 201
586-046	U101, 201
586-871	U1
5299999-347	C3, 12, 13, 16, 115, 215, 112, 212
030-945	C110, 210
173-013	TP 1, 2, 3, 4
055-547	C106, 206
5299999-414	C*
013-358	VR 2
5299998-181	R 2
5299997-242	R 102, 202
5299997-391	R 110
034-222	C 108

- ① RESISTORS R 101, 201 WILL BE SELECTED BY TEST AND PICKED OUT OF KIT P/N 5203338-01 DELIVERED WITH THIS PCBA
- ② MARK DASH NO AND ISSUE LETTER WITH WHITE INK PER AMPEX STANDARD BD-1
- ③ PLUS SIGN ON CAPACITOR INDICATES POSITIVE
- 5-FOR BM SEE 5203330
 4-FOR SCHEMATIC SEE 5203331
 3-FART NO TO BE 5203330-01
 2-COMPONENT DESIGNATIONS ARE FOR REF ONLY
 1-ASSEMBLE PER AMPEX STANDARDS HC 2-2
- NOTES:

173-012
4 PLC'S

173-013
4 PLC'S

180-769

172-625
501-185 2 RD D
502-002
492-008
2 PLACES

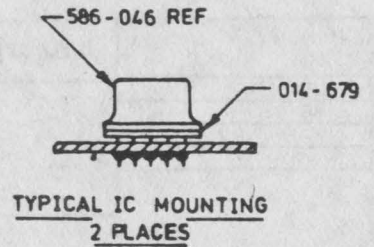

CAPACITY, PLATE NOT SHOWN FOR CLARITY

5203330	YM 100
DATE	
APP	

DO NOT SCALE DRAWING
UNLESS OTHERWISE SPECIFIED
DIMENSIONS ARE IN MILLIMETERS

DESIGNED BY: [Signature]
 CHECKED BY: [Signature]
 DRAWN BY: [Signature]
 DATE: [Signature]

AMPEX ELECTRONICS

DESIGNED BY: LEMINEUR
 CHECKED BY: QUINET
 DRAWN BY: MARRONE
 DATE: MAEGERMAN

AMPEX ELECTRONICS

PCBA LOOP SENSOR
ELECTRONICS

REV: C
 DATE: 5203332
 SHEET: 1 OF 2

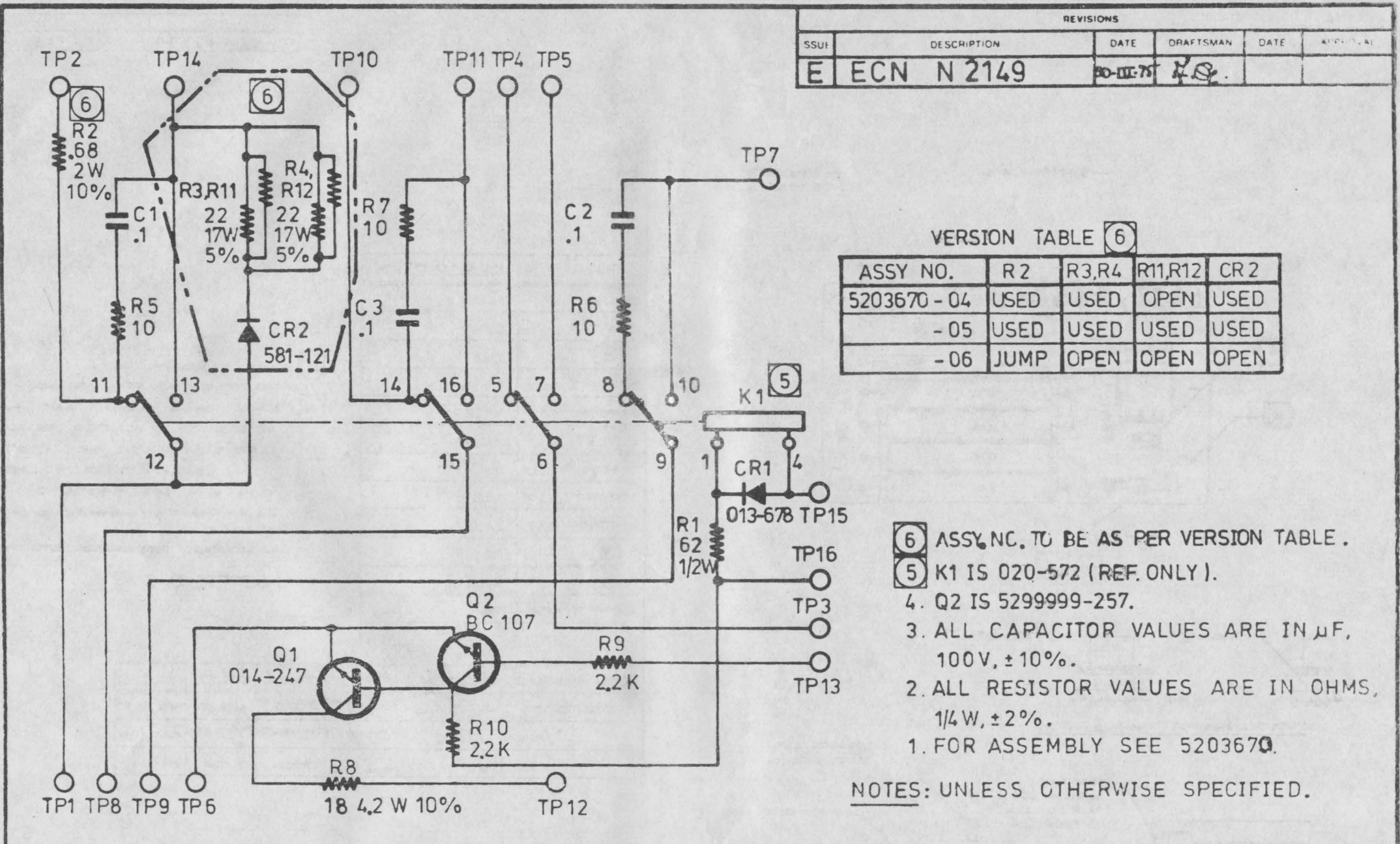

REVISIONS					
SSUI	DESCRIPTION	DATE	DRAFTSMAN	DATE	APPROVAL
E	ECN N 2149	30-III-75	[Signature]		

VERSION TABLE ⑥

ASSY NO.	R 2	R3,R4	R11,R12	CR 2
5203670 - 04	USED	USED	OPEN	USED
- 05	USED	USED	USED	USED
- 06	JUMP	OPEN	OPEN	OPEN

- ⑥ ASSY. NO. TO BE AS PER VERSION TABLE.
- ⑤ K1 IS 020-572 (REF. ONLY).
- 4. Q2 IS 5299999-257.
- 3. ALL CAPACITOR VALUES ARE IN μ F, 100V, \pm 10%.
- 2. ALL RESISTOR VALUES ARE IN OHMS, 1/4 W, \pm 2%.
- 1. FOR ASSEMBLY SEE 5203670.

NOTES: UNLESS OTHERWISE SPECIFIED.

LAST USED	DELETED
R12	
C3	
CR2	
Q2	
K1	

DO NOT SCALE DRAWING
 UNLESS OTHERWISE SPECIFIED
 DIMENSIONS ARE IN INCHES

DECIMALS TOLERANCES ANGLES
 XX ± XXX ±

BREAK ALL SHARP EDGES APPROX .010 C BORE
 AND SPOTFACE CORNER RADII APPROX .010
 ROUGHNESS OF ALL MACHINED SURFACES PER MIL STD-10

MATERIAL

FINISH

THE INFORMATION HEREON IS THE PROPERTY OF
 AMPEX COMPUTER PRODUCTS DIVISION NO RE
 PRODUCTION OR UNAUTHORIZED USE IN PART OR
 IN WHOLE SHALL BE MADE WITHOUT WRITTEN
 CONSENT OF AMPEX CORPORATION

DWG NO 5203671

PROJ ENGR
 ENGR
 CHKR
 DFTSMN GREGOIRE. 28-74

MODEL

T M STACK
 VIDEO AUDIO PROF
 INSTRU CONS

AMPEX S.A. NIVELLES BELGIUM

TITLE
SCHEMATIC RELAY BOARD

BM NO BM SIZE DWG NO
 ON DWG SEPARATE **A** 5203671 E
 REF DWG SCALE NONE SHEET 1 OF 1

5203670	TM 100
NEXT ASSY	1 ST USED ON
APPLICATION	

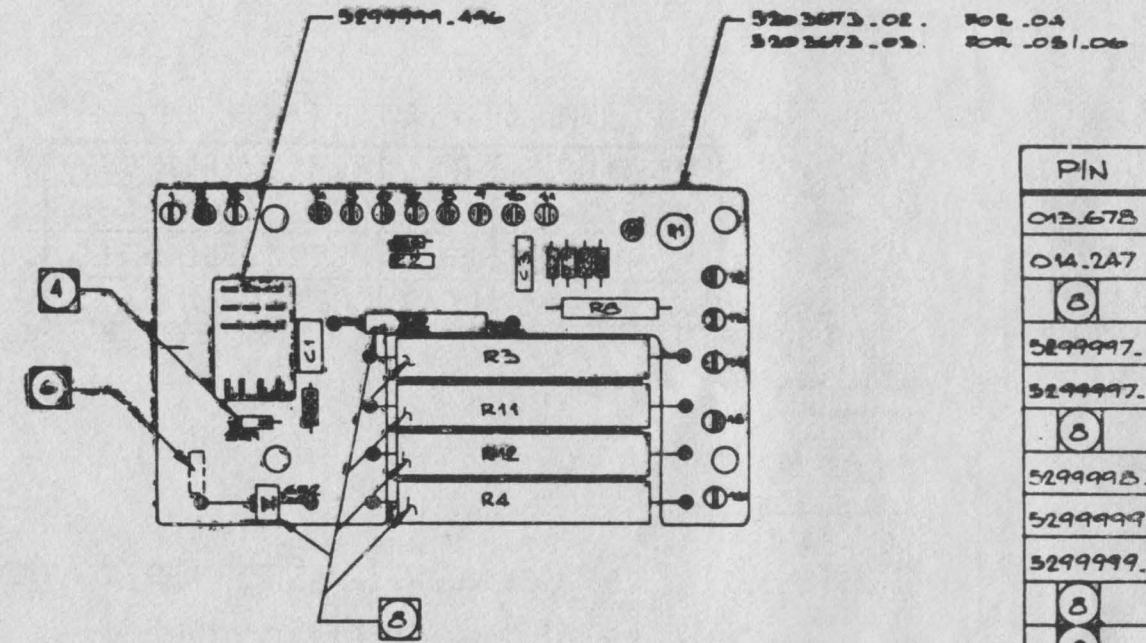

PIN	DESCRIPTION
013.678	CR1
014.2A7	Q1
Ⓟ	CR2
529999.100	R3,6,7
529999.282	R9,R10
Ⓟ	R11,12
529999.620	R1
529999.257	Q2
529999.347	C1,2,3
Ⓟ	R2
Ⓟ	R3A
529999.481	R5

- Ⓟ SEE VERSION TABLE
- 7 PIN TO BE AS PER VERSION TABLE
- Ⓞ MARK DASH NUMBER AND ISSUE LETTER WITH WHITE INK PER BDA-1
- 5. FOR SCHEMATIC SEE 5203671.
- Ⓞ HEAVY LINE ON DIODE INDICATES CATHODE
- 3. FOR DIM SEE 5203670
- 2. COMPONENT DESIGNATIONS ARE FOR REF. ONLY.
- 1 ASSEMBLE PER AMPLEX STD MCR.2

NOTES:

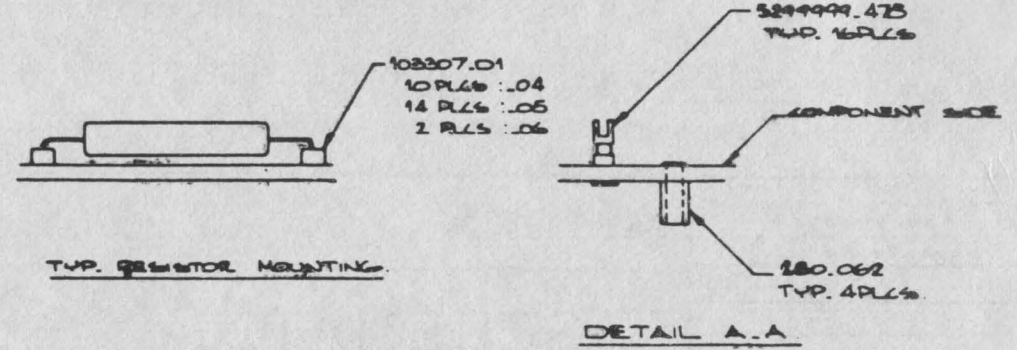
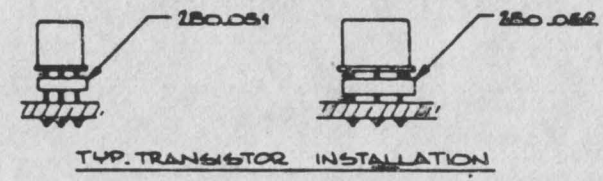

ASSY NUMBER	FUNCTION	R2	R3,R4	R11,12	CR2
5203670.04	MERCURE	529999.475	529999.480	NONE	529.121
.05	AUTO	529999.475	529999.480	529999.480	529.121
.06	NON AUTO	JUMP 614.762	OPEN	OPEN	OPEN

DO NOT SCALE DRAWING
 UNLESS OTHERWISE SPECIFIED

AMPEX ...

PCBA - RELAY BO
 REF. DWG.

5203670 TADDO

C 5203672 F

REVISIONS				
S	DESCRIPTION	DATE	DRAFTSMAN	APPROVAL
A	ERN N 1302			
B	ECN N 1742			
C	ECN N 1806	2/11/64	LY	
D	ECN N 1898	3/17/64	R.T.	
E	ECN N 2527	22 MAR 64	RR	

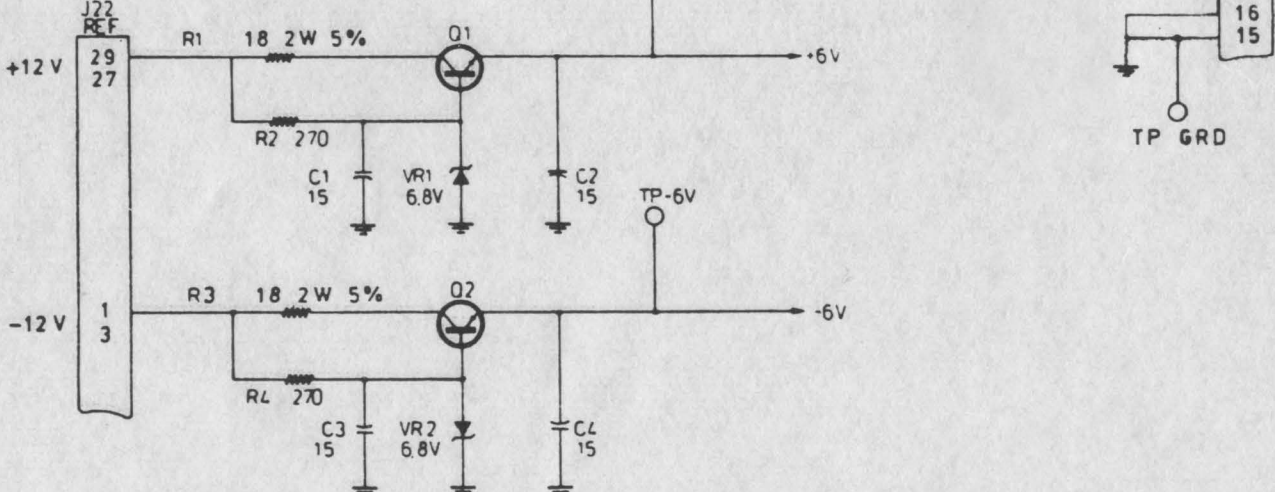
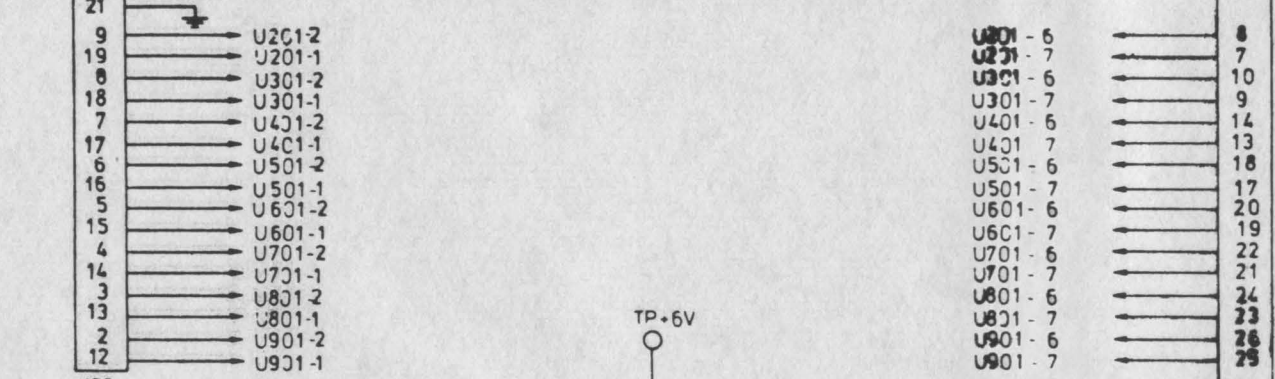
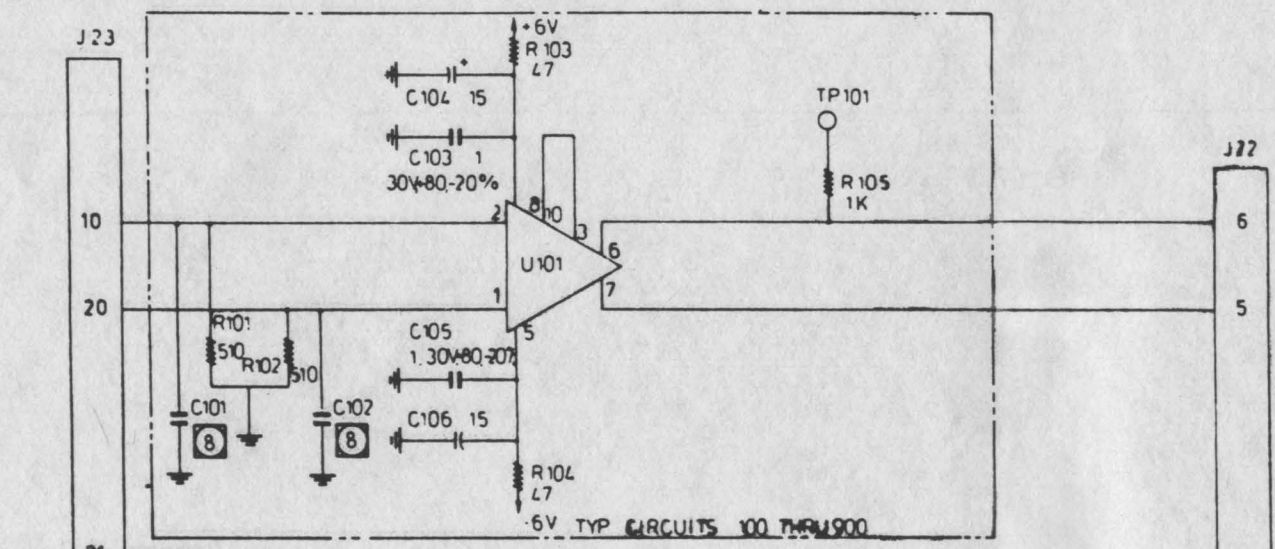

LAST USED	DELETED	NOT USED
TP101 TH901		
C106 TH906		
U901		
R105 TH905		
R4		
VR2		
C4		
Q2		
TP GRD.		
TP-6V, TP+6V		

- ⑧ OPEN FOR -01
PIN 034-177 FOR -02.
- 7. ALL IC ARE 586-289 (µA733)
- 6. Q2 IS 014-364
- 5. O1 IS 014-247
- 4. ALL DIODES TO BE 013-274
- 3. ALL CAPACITOR VALUES ARE IN MICROFARADS. 20V, ±10%
- 2. ALL RESISTOR VALUES ARE IN OHMS, 1/4W, ±2%
- ① FOR ASSEMBLY SEE VERSION TABLE.

NOTES

VERSION TABLE ①

FUNCTION	ASSY NO.
TM 100 & TME LO. SPEED	5203325 - 01
TME HI. SPEED	5203325 - 02

PREAMPLIFIER

DO NOT SCALE DRAWING UNLESS OTHERWISE SPECIFIED		5203326		AMPEX SA BRUXELLES BELGIUM	
DESIGNED BY: LEMINEUR		DRAWN BY: DEBAISIEUX		SCHEMATIC	
CHECKED BY: MARRONE		APPROVED BY: MATHUES		READ PREAMPLIFIER	
PART NO. 5203325		REV. 01		C 5203325 E	
NEXT ASSY. LISTED ON		APPLICATION		NONE	

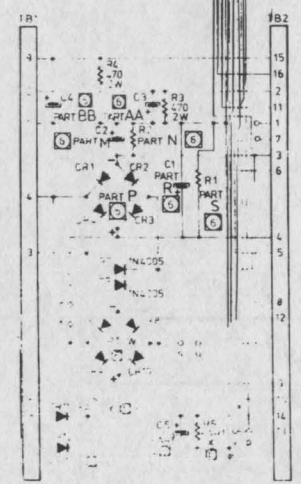
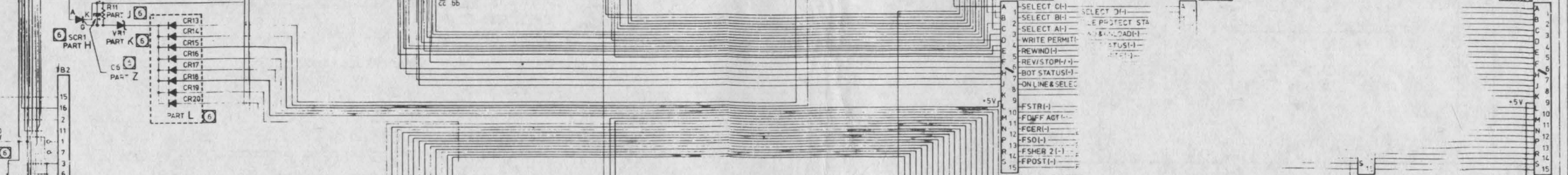
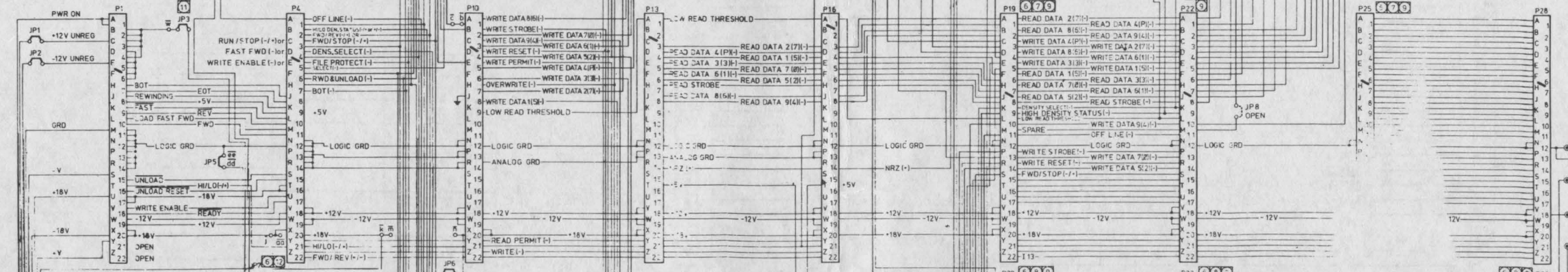
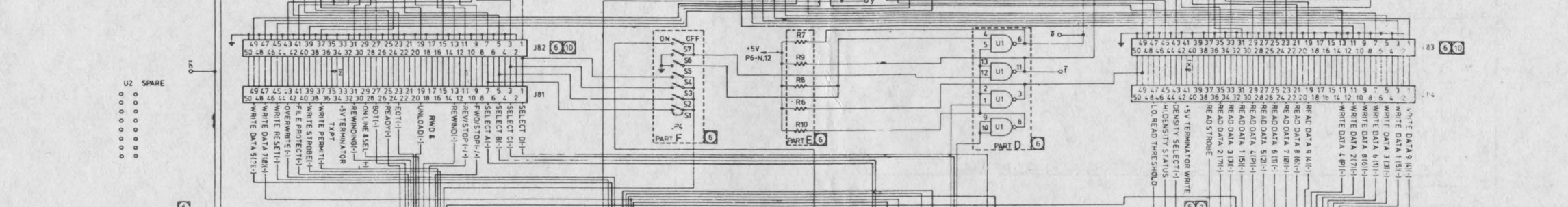
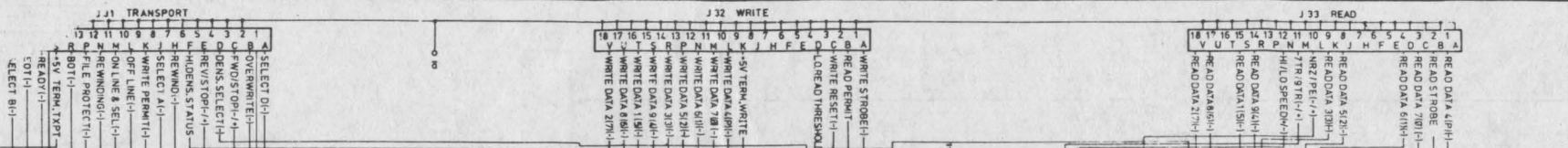

TP +5V
 TP +12V
 TP +18V

5204182

REVISIONS		SIGNATURE AND DATE		
LTA	ZONE	DESCRIPTION	DFTG	ENR
C		ECN N2708-9 RERAWN NO CHANGE		

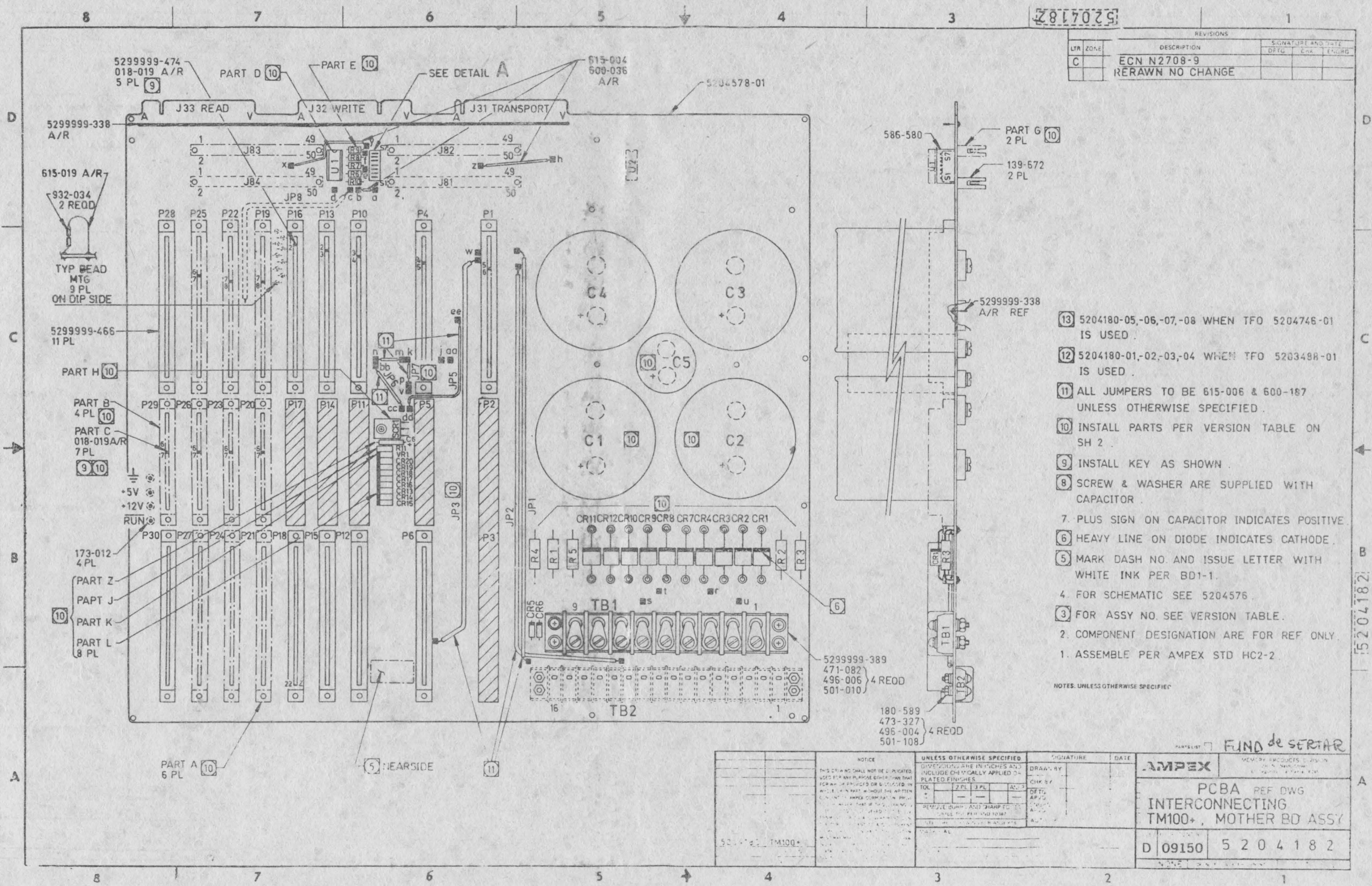

- 13 5204180-05,-06,-07,-08 WHEN TFO 5204746-01 IS USED.
- 12 5204180-01,-02,-03,-04 WHEN TFO 5203488-01 IS USED.
- 11 ALL JUMPERS TO BE 615-006 & 600-187 UNLESS OTHERWISE SPECIFIED.
- 10 INSTALL PARTS PER VERSION TABLE ON SH 2.
- 9 INSTALL KEY AS SHOWN.
- 8 SCREW & WASHER ARE SUPPLIED WITH CAPACITOR.
- 7. PLUS SIGN ON CAPACITOR INDICATES POSITIVE.
- 6 HEAVY LINE ON DIODE INDICATES CATHODE.
- 5 MARK DASH NO. AND ISSUE LETTER WITH WHITE INK PER BD1-1.
- 4. FOR SCHEMATIC SEE 5204576.
- 3 FOR ASSY NO. SEE VERSION TABLE.
- 2. COMPONENT DESIGNATION ARE FOR REF ONLY.
- 1. ASSEMBLE PER AMPEX STD HC2-2.

NOTES: UNLESS OTHERWISE SPECIFIED

NOTICE THIS DRAWING SHALL NOT BE REPRODUCED, COPIED, OR TRANSMITTED IN ANY FORM OR BY ANY MEANS, ELECTRONIC OR MECHANICAL, INCLUDING PHOTOCOPYING, RECORDING, OR BY ANY INFORMATION STORAGE AND RETRIEVAL SYSTEM, WITHOUT THE WRITTEN PERMISSION OF AMPEX CORPORATION.	UNLESS OTHERWISE SPECIFIED DIMENSIONS ARE IN INCHES AND INCLUDE CHYMICALLY APPLIED OR PLATED FINISHES. TOL: 2 PL 3 PL REMOVE BURR AND SHARP EDGES.	SIGNATURE DATE DRAWN BY CHK BY DFTG APVD AUTH	PART LIST FIND de SERTAR	
			AMPEX MEMORY PRODUCTS DIVISION 200 S. MAIN ST. ANAHEIM, CALIF. 92801	
PCBA REF DWG INTERCONNECTING TM100+, MOTHER BOARD ASSY			D 09150 5 2 0 4 1 8 2	

5203816

REVISIONS		SIGNATURE AND DATE		
LTR	DESCRIPTION	DATE	CHK	ENGRG
M	SEE 3001			

■ DENOTES INTERNAL OUTPUT SIGNAL
 ○ DENOTES INTERNAL INPUT SIGNAL

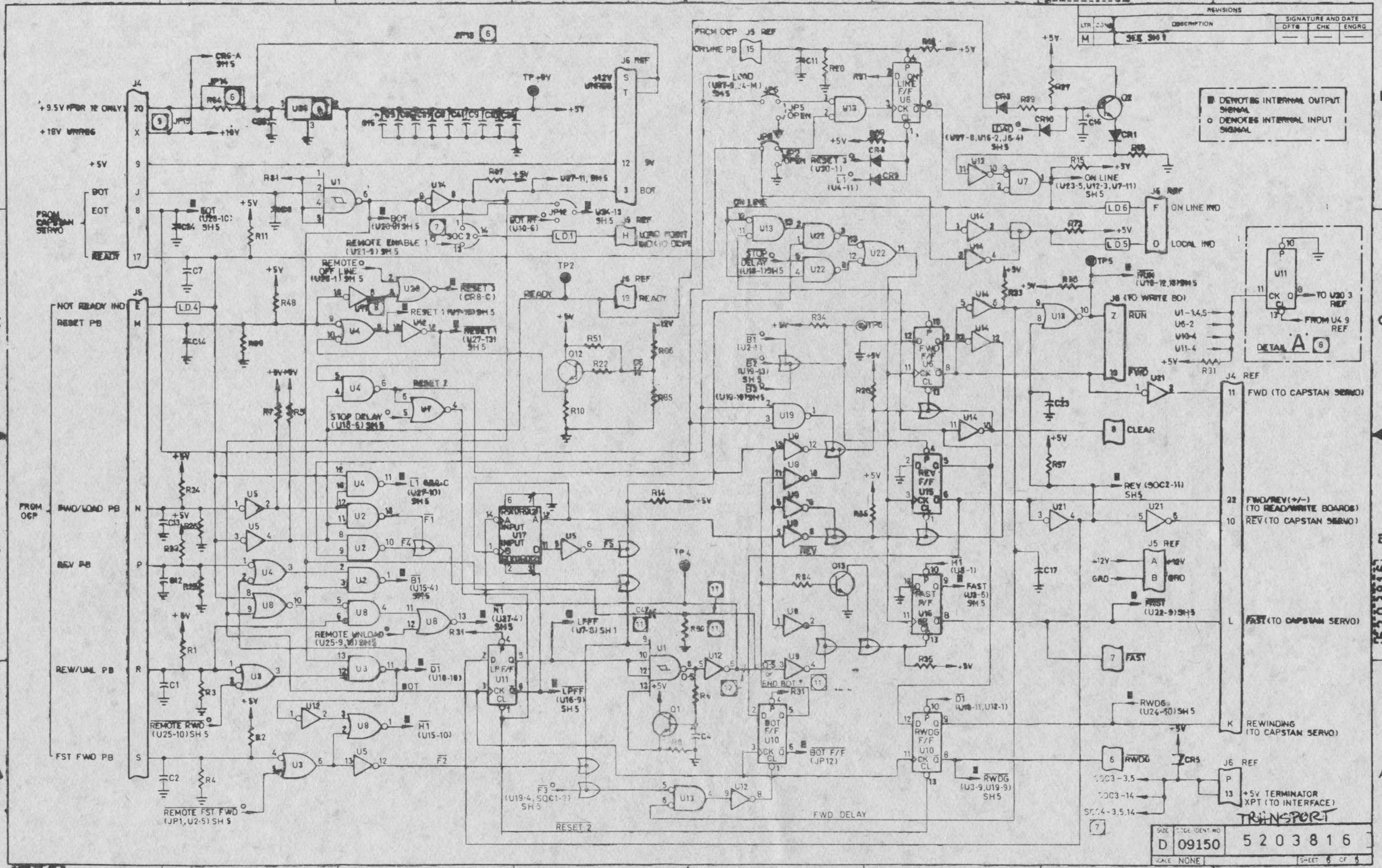

SIZE	EDGE IDENT NO	5203816
D	09150	
SCALE	NONE	
		SHEET 6 OF 8

TRANSPORT

5203316

REVISIONS		DATE	BY	CHKD	ENGR
LTR	ZONE	DESCRIPTION			
M		SEE SH 1			

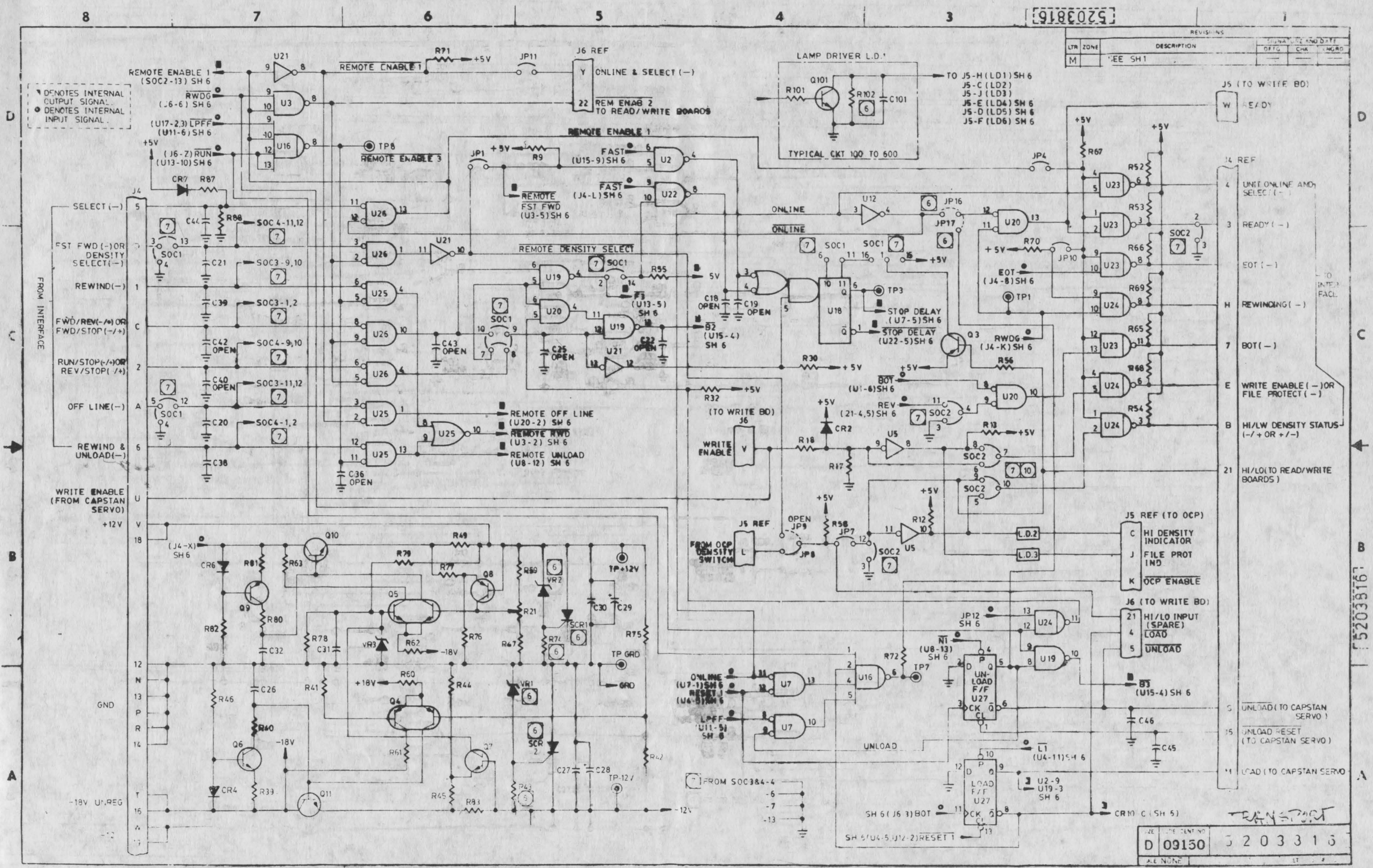

RELAY	DESCRIPTION	TO
J5	(TO WRITE BOARD)	W READY
J5	REF	4 UNIT ONLINE AND SELECT (-)
		3 READY (-)
		EOT (-)
		H REWINDING (-)
		7 BOT (-)
		E WRITE ENABLE (-) OR FILE PROTECT (-)
		B HI/LW DENSITY STATUS (-/+ OR +/-)
		21 HI/LO (TO READ/WRITE BOARDS)
J5	REF (TO OCP)	C HI DENSITY INDICATOR
		J FILE PROT IND
		K OCP ENABLE
J6	(TO WRITE BOARD)	21 HI/LO INPUT (SPARE) LOAD
		4 UNLOAD
		5 UNLOAD (TO CAPSTAN SERVO)
		15 UNLOAD RESET (TO CAPSTAN SERVO)
		11 LOAD (TO CAPSTAN SERVO)

REV	DATE	REV	DATE
D	09150	5	203316
AE	NONE	ST	

5203316

REVISIONS		SIGNATURE AND DATE			
LTR	ZONE	DESCRIPTION	DFTG	CHK	ENGRG
1		SEE SHEET ONE			

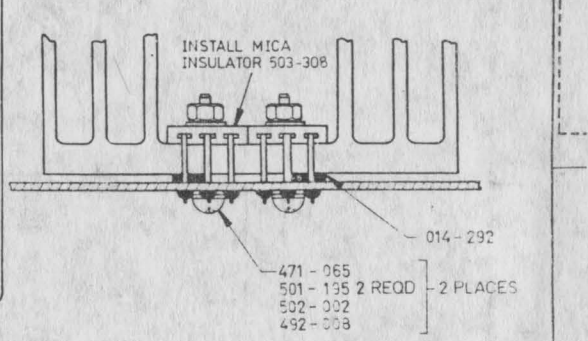
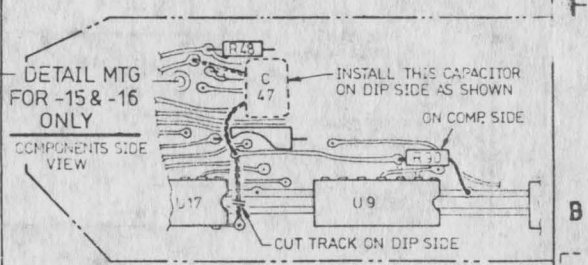
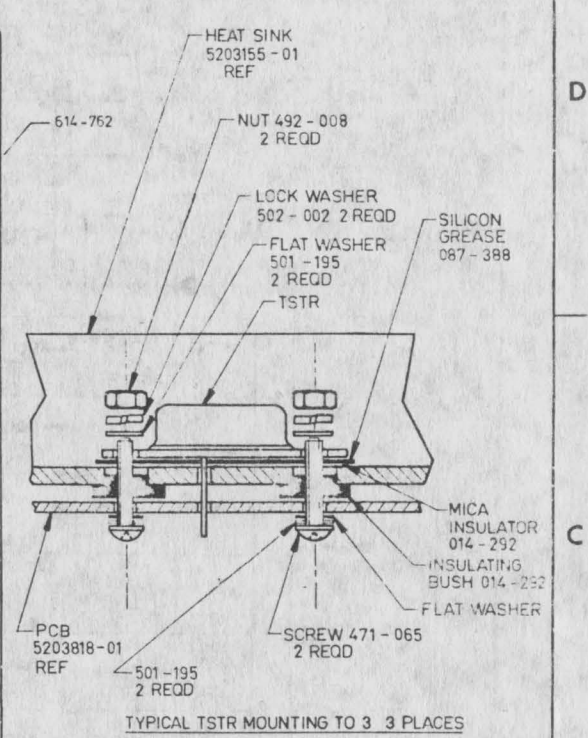
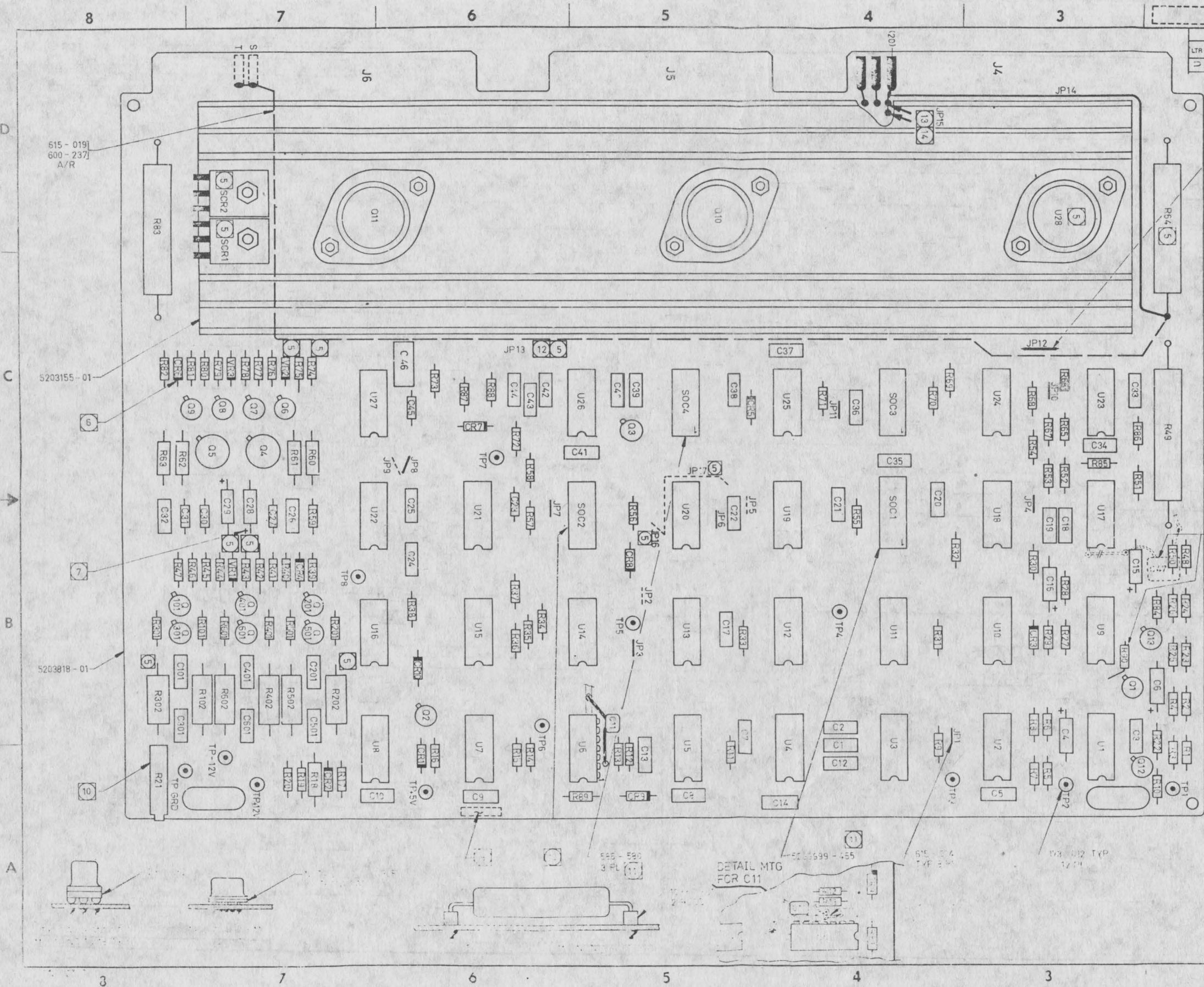

615-019
600-237
A/R

5203155-01

5203818-01

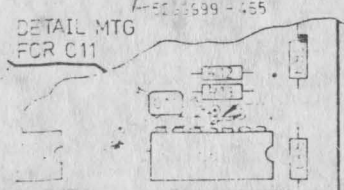

TRANSPORT

REV	DATE	DESIGN NO	5203817
D	09150		

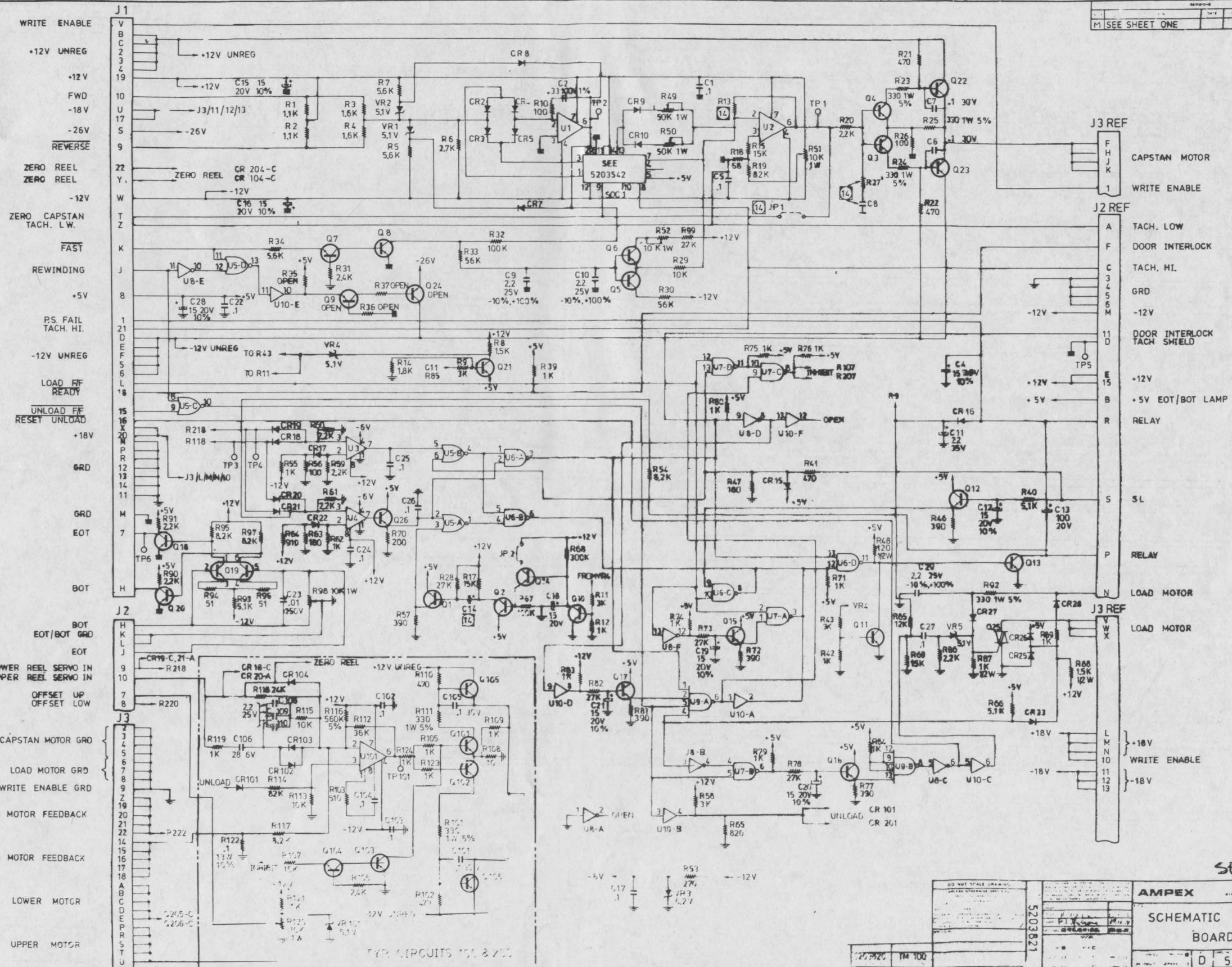

FOR CIRCUITS 100 & 200

SERVO

DO NOT SCALE DRAWING UNLESS OTHERWISE SPECIFIED	5203821	AMPEX AVILLER BELLEVILLE
SCHEMATIC SERVO BOARD		
D 5203321		

REVISIONS				
NO.	DESCRIPTION	DATE	DRAFTSMAN	APPROVER
1	L SEE SHEET ONE			

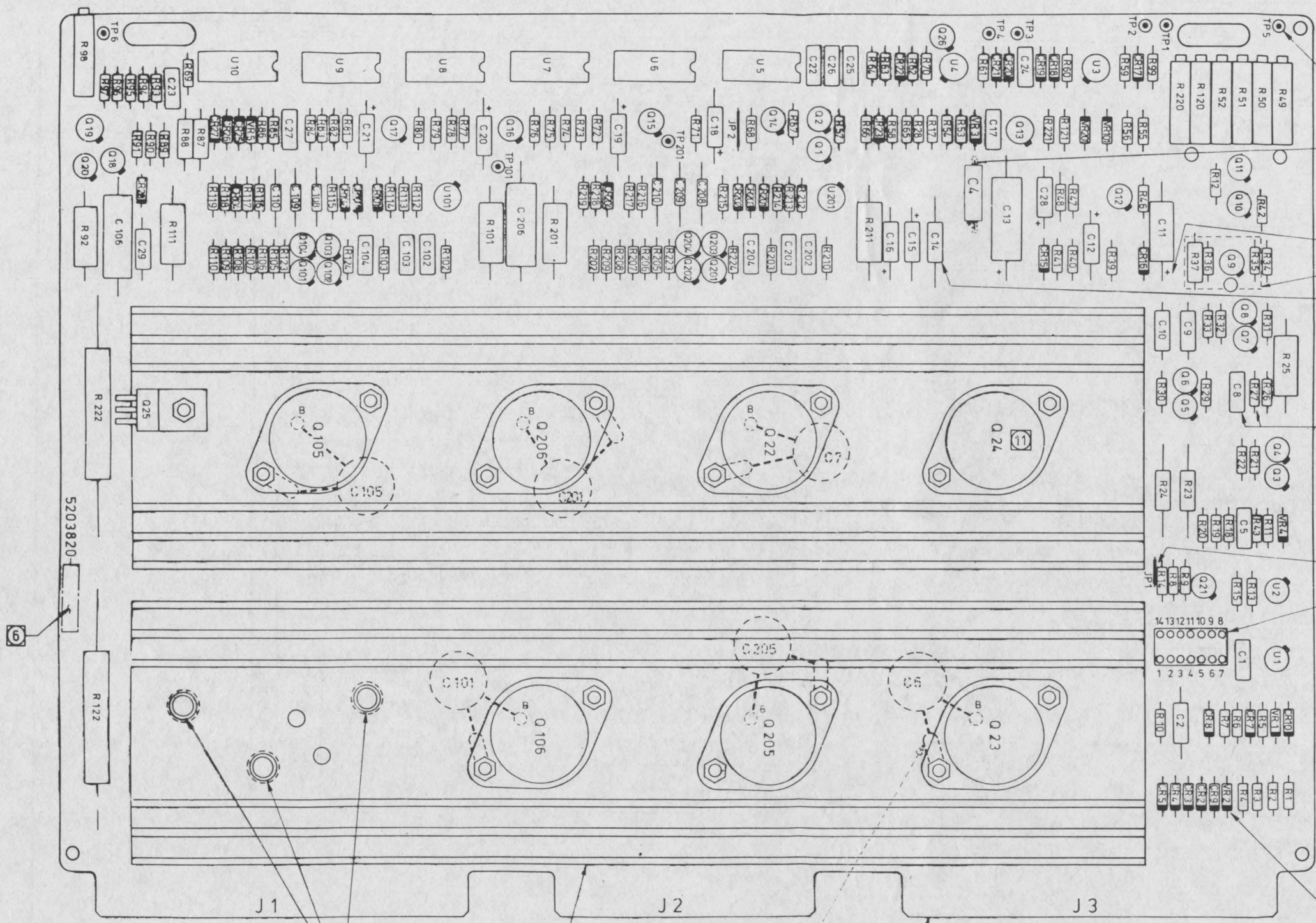

173-012
8 PLS.

600-036
A/R

7
11
9

9

9

5299999-386

8

INSTALL INSULATING
BUSH 3 PLS
014-292 2RQ'D

5203341-01
2 PLS

172-008
5 PLS

5203823-01

SIZE	CODE	REV. NO.	
D	09150	5203822	
SCALE	NONE	SET 2	

SERVO

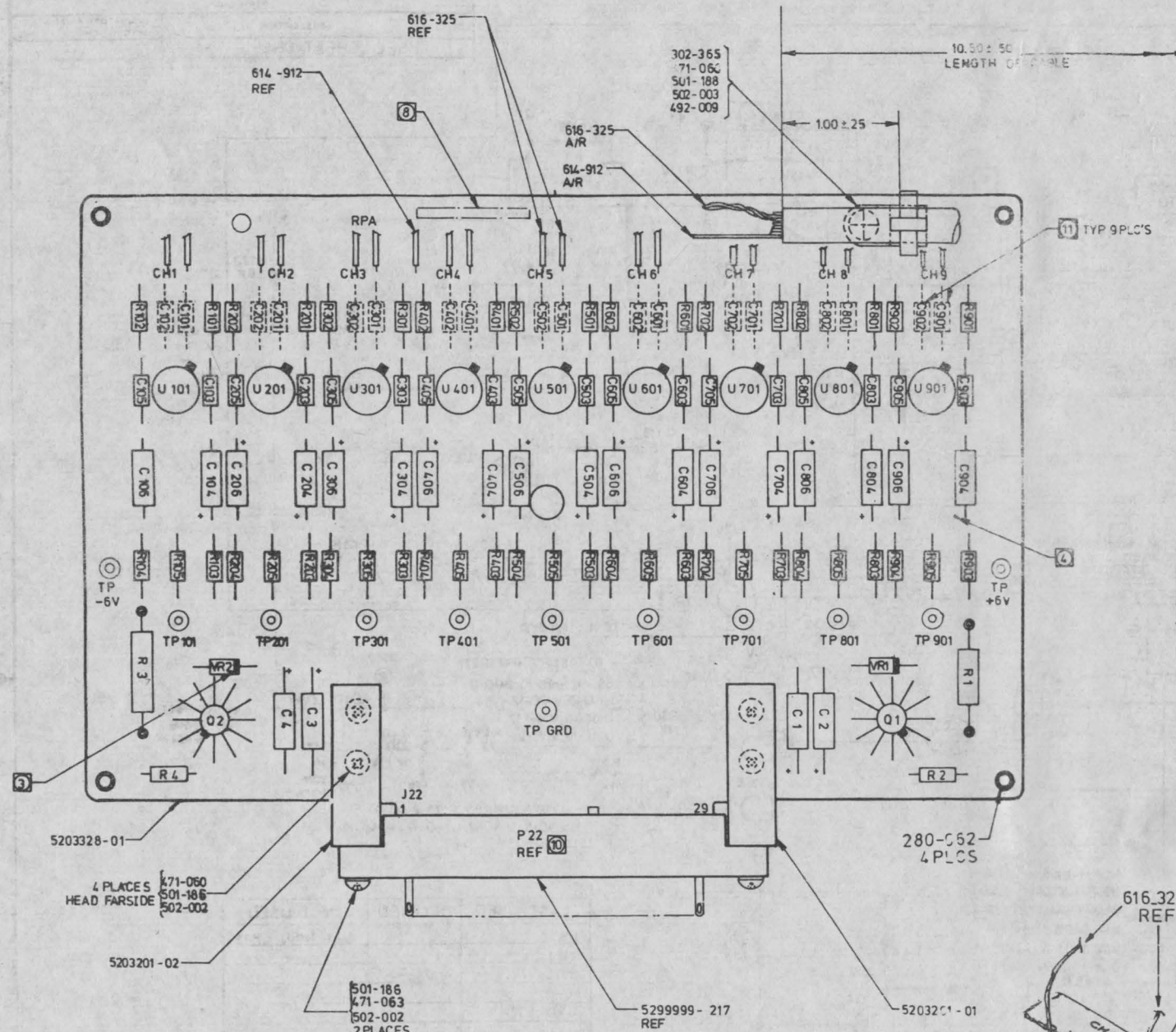

WIRING CHART

WIRE PAIR	CONDUCTOR COLOR	CONNECTOR J23 TERMINAL
CH1	WHITE	10
	GREY	20
CH2	WHITE	9
	GREY	19
CH3	WHITE	8
	GREY	18
CH4	WHITE	7
	GREY	17
CH5	WHITE	6
	GREY	16
CH6	WHITE	5
	GREY	15
CH7	WHITE	4
	GREY	14
CH8	WHITE	3
	GREY	13
CH9	WHITE	2
	GREY	21

PART NO	REFERENCE DESIGNATION
5299999-250	C 103, 105 THRU C 903, 905
013-224	VR 1, 2
014-247	Q1
014-364	Q2
037-985	C1, 2, 3, 4, C104, 106 THRU 904, 906
5299997-102	R105 THRU S05
5299997-470	R103, 104 THRU 903, 904
5299997-511	R101, 102 THRU 901, 902
173-012	TP101 THRU TP901, TP-6V, TP-6V, GRD
586-289	U101 THRU U901
041-669	R1, R3
5299997-271	R2, R4
(11)	C101, 102 THRU C901, 902

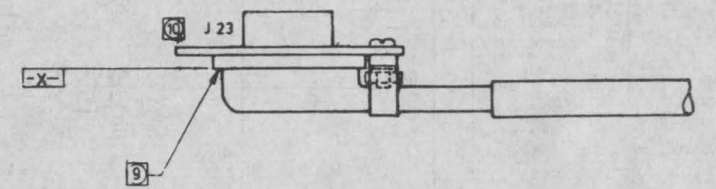
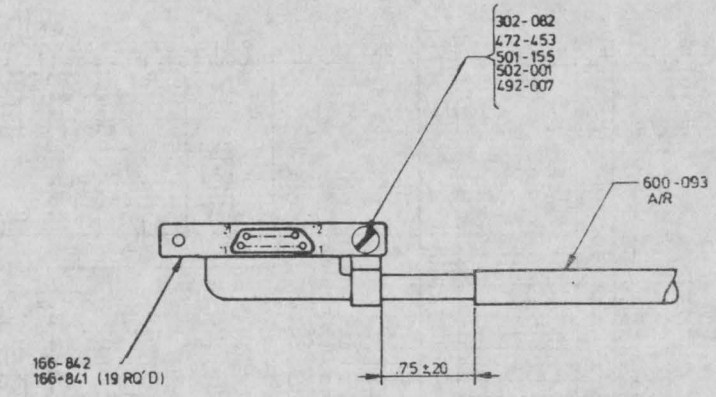

- NOTES:
- (11) OPEN FOR -01
PIN 034-177 FOR -02.
 - (10) MARK REFERENCE DESIGNATIONS PER AMPEX SPEC 3128856, PARA 3.1
 - (9) AFTER INSERTING WIRES, POT AREA INDICATED WITH EPOXY 2651-MM (922-327) OR EQUIVALENT.
POTTING COMPOUND NOT TO PROTRUDE BEYOND SURFACE -X-
 - (8) MARK PART NUMBER 5203325-01 AND ISSUE LETTER WITH WHITE INK PER B01-1
 - (7) FOR B/M SEE VERSION TABLE.
 - 6 - FOR WIRE LIST SEE 5203415
 - 5 - COMPONENTS DESIGNATIONS ARE FOR REF ONLY
 - (4) PLUS SIGN ON CAPACITOR INDICATES POSITIVE
 - (3) HEAVY LINE ON DIODE INDICATES CATHODE
 - 2 - ASSEMBLE & FABRICATE PER AMPEX HC2-2
 - 1 - FOR SCHEMATIC SEE 5203326

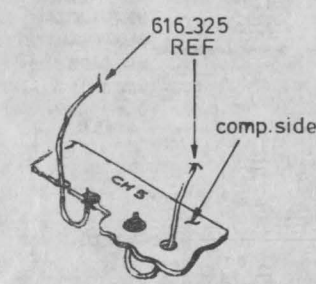

VERSION TABLE (7)

FUNCTION	ASSY NO.
TM 100 & TIME I.O. SPEED	5203325-01
TIME HI. SPEED	5203325-02

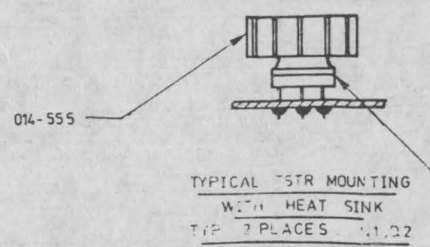
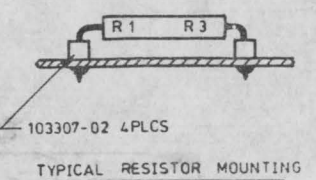

DO NOT SCALE DRAWING		AMPEX	
5203327		PCBA READ PREAMPLIFIER	
5203327		5203327 G	

REV	ZONE	DESCRIPTION	SIGNATURE AND DATE
5		SEE SHEET ONE	

TYPICAL 9 CIRCUITS

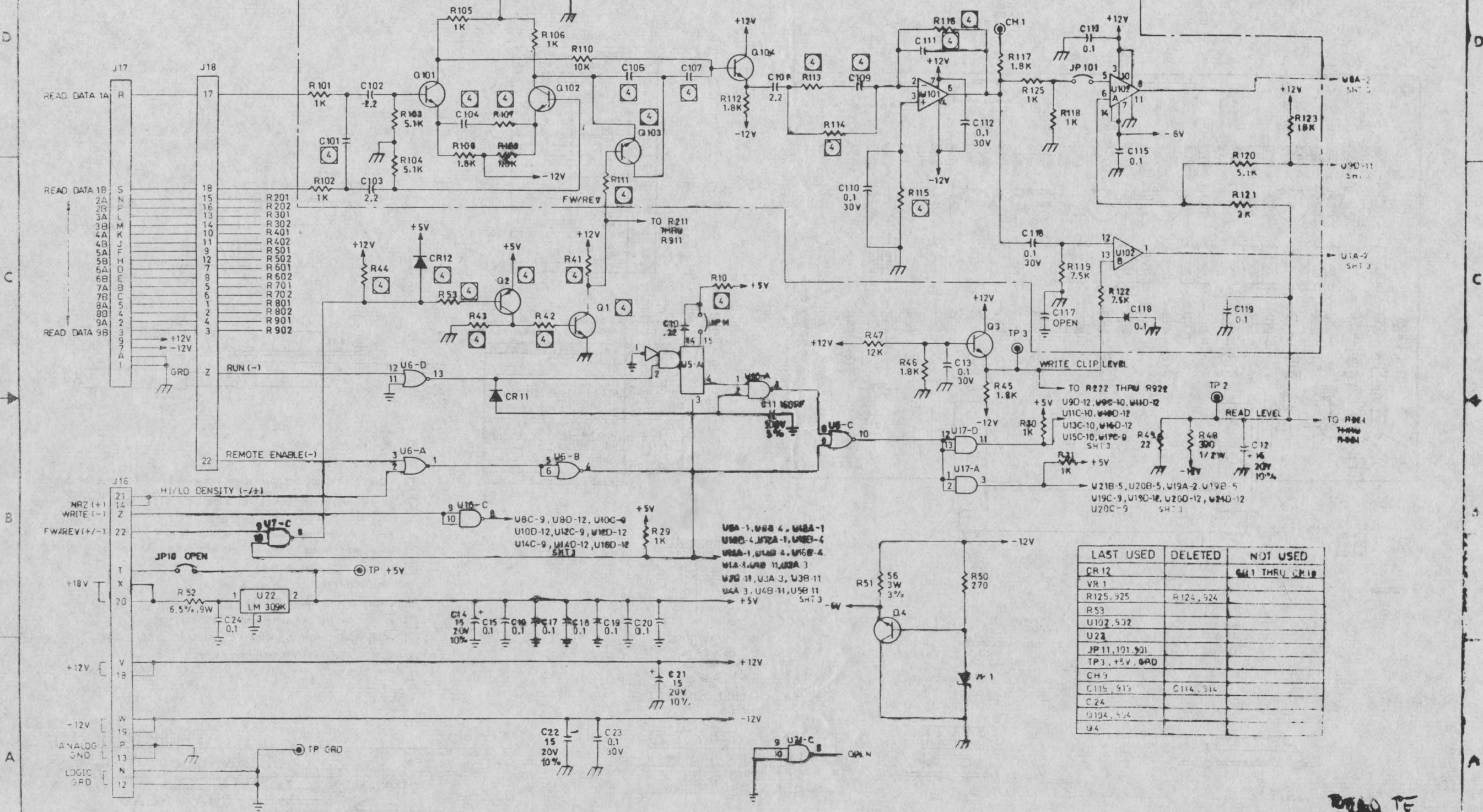

LAST USED	DELETED	NOT USED
CR12		CR11 THRU CR18
VR1		
R125, 925	R124, 524	
R53		
U102, 532		
U22		
JP11, 101, 901		
TP3, +5V, 6AD		
CH3		
C115, 915	C114, 914	
C24		
Q104, 514		
Q4		

READ TE
 D 09150 5203516

REVISIONS			SIGNATURE AND DATE		
LTN	DATE	DESCRIPTION	DFTG	CHK	ENGRG
5		SEE SHEET ONE			

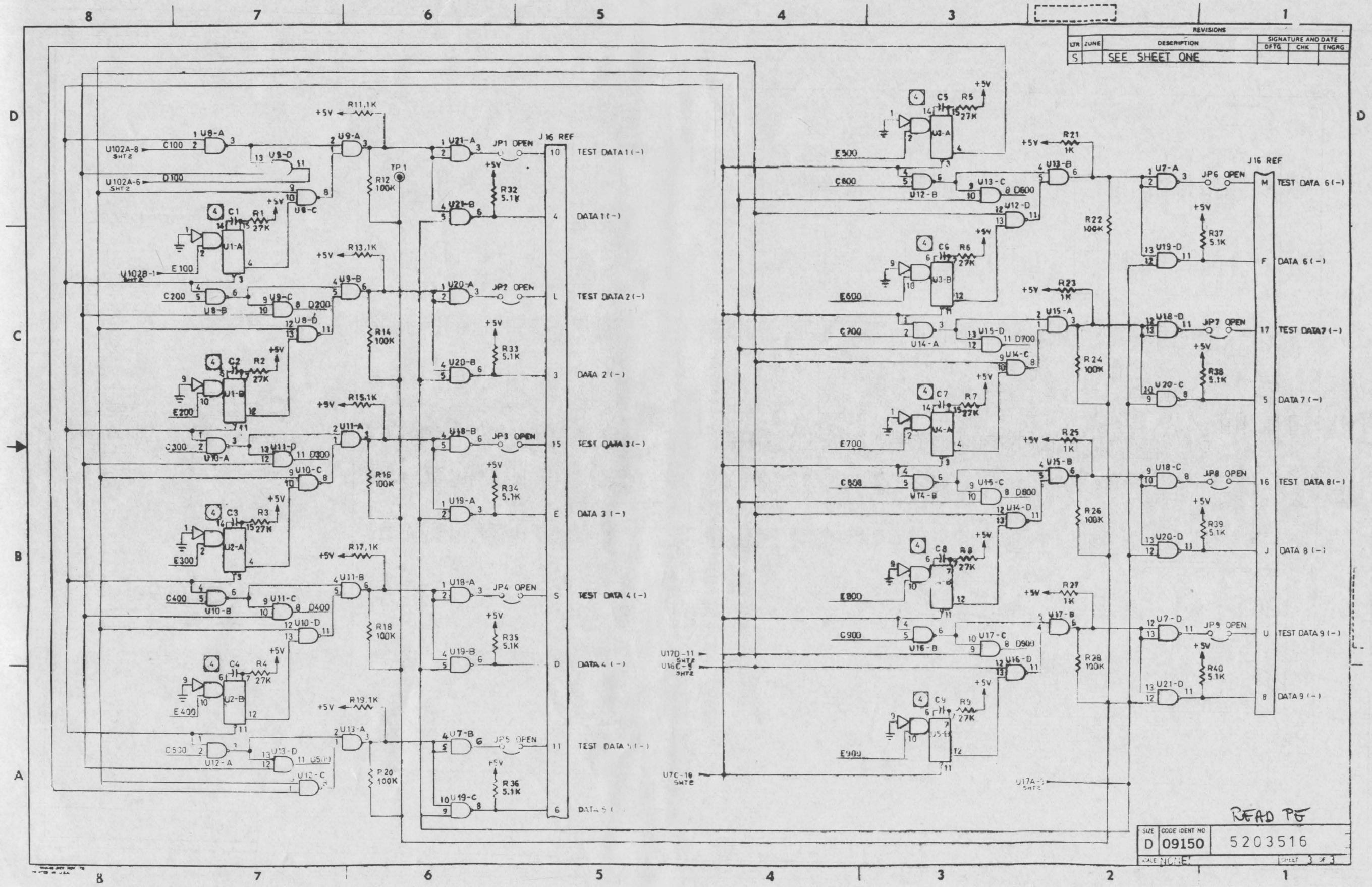

READ PG

SIZE	CODE IDENT NO	
D	09150	5203516
SCALE	NONE	SHEET 3 OF 3

REVISIONS			SIGNATURE AND DATE		
LTR	ZONE	DESCRIPTION	DFTG	CHK	ENGRG
5		SEE SHEET ONE			

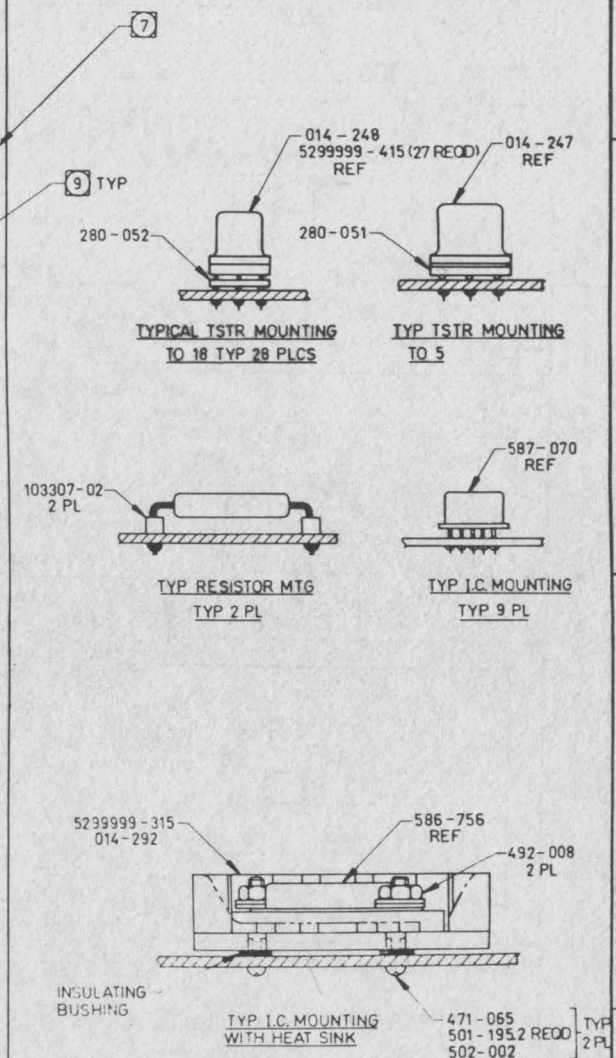
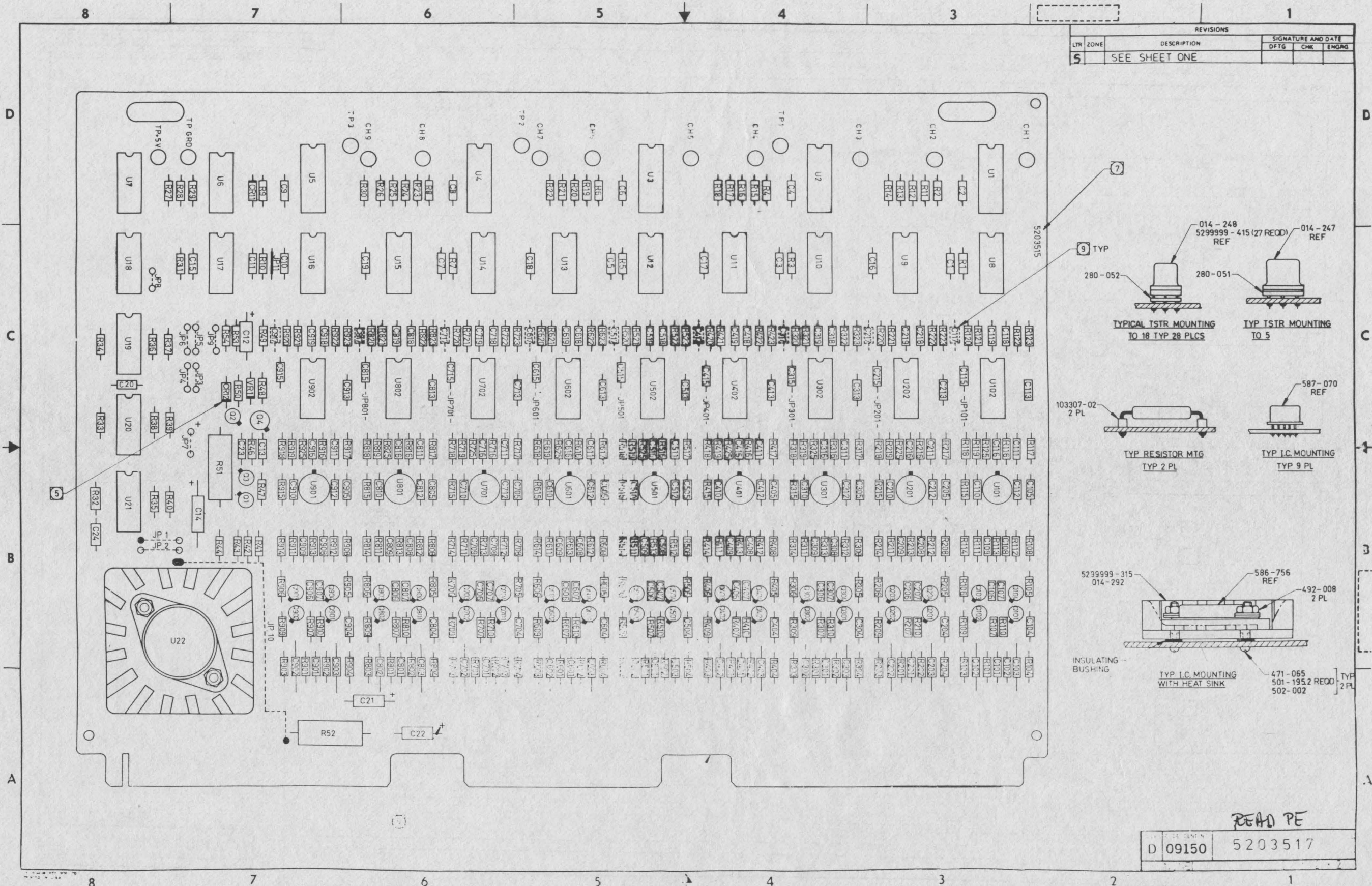

READ PE

D 09150 5203517

REVISIONS			SIGNATURE AND DATE		
LTR	ZONE	DESCRIPTION	DTG	CHK	ENGRG
		SHEET ONE			

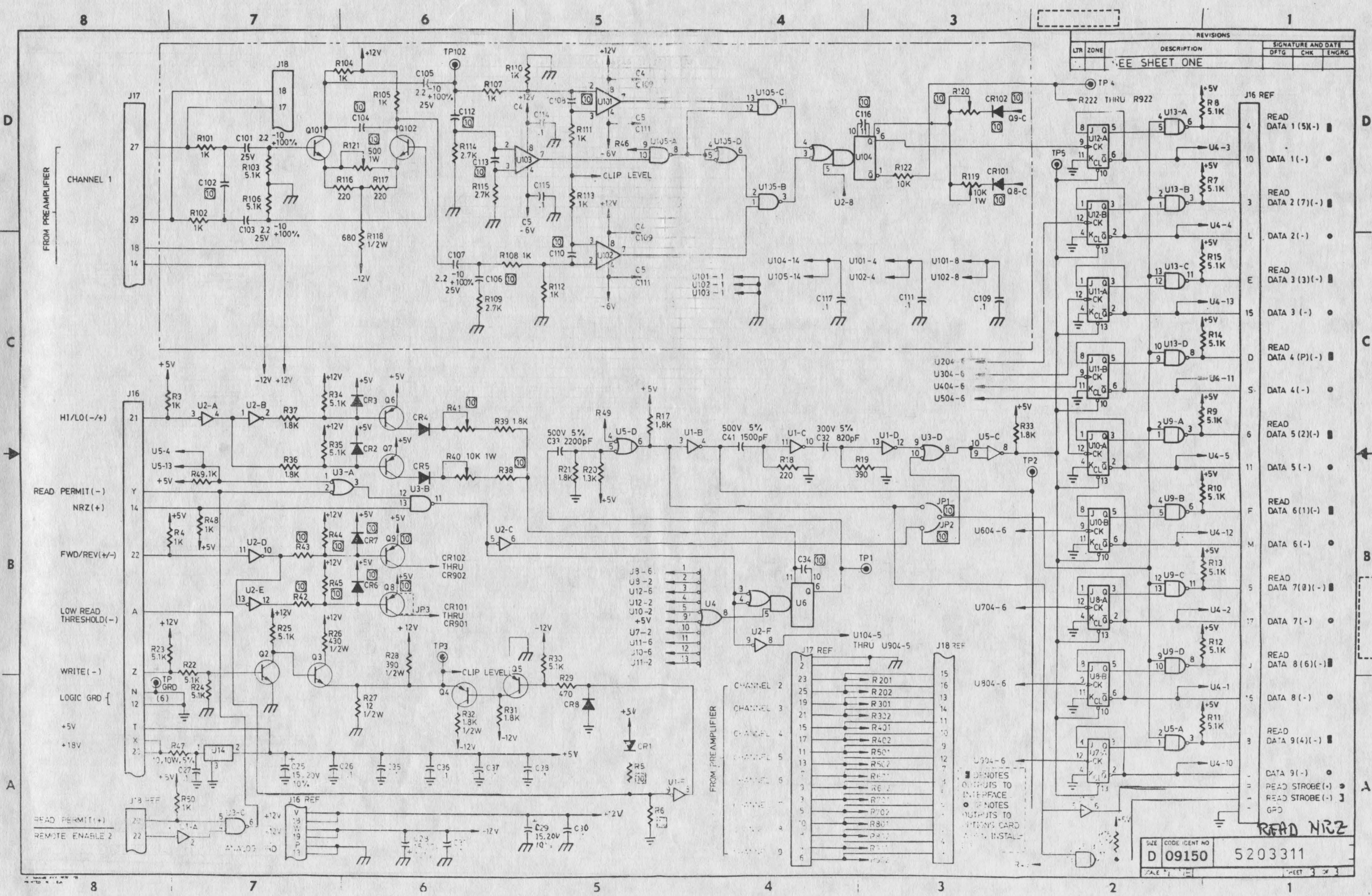

READ NRZ

SIZE	CODE	IDENT NO	
D	09150	5203311	
PAGE 1		SHEET 3 OF 3	

REVISIONS			SIGNATURE AND DATE		
LTR	ZONE	DESCRIPTION	DTG	CHK	ENGRG
		SEE SHEET ONE			

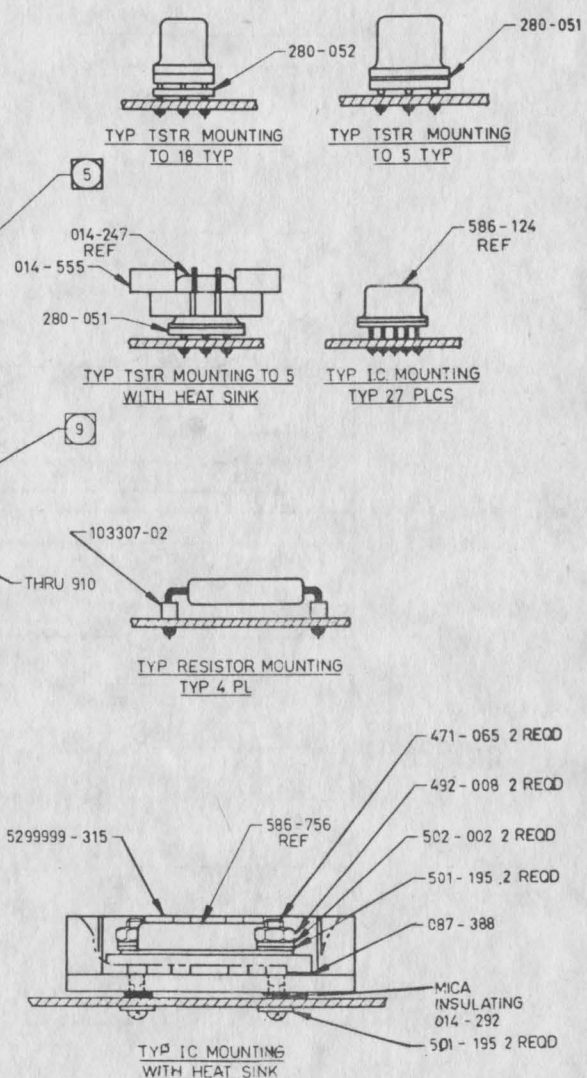
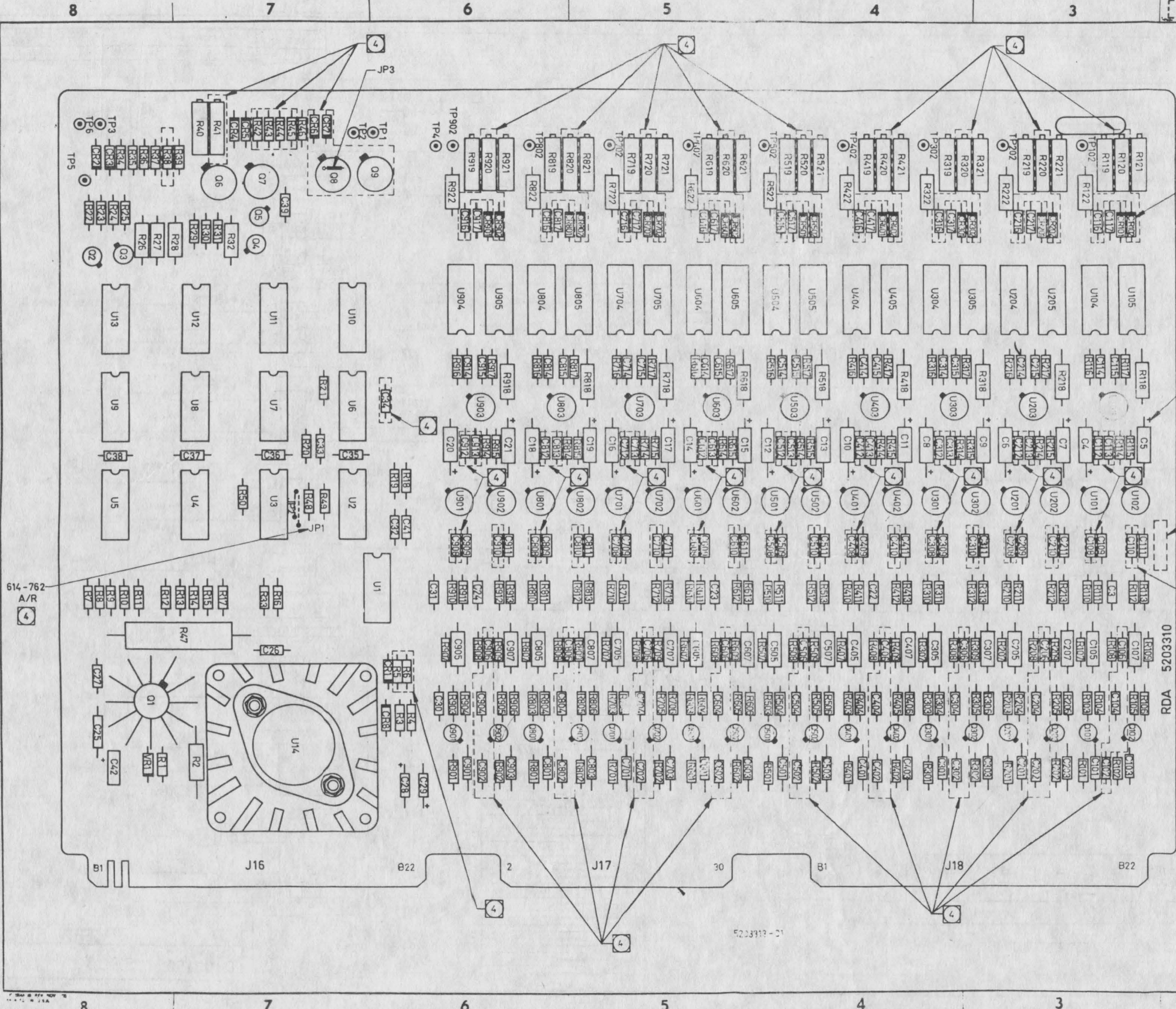

614-762
A/R

523312-01

READ HRZ

SIZE	CODE	QTY	NO
D	09150	5203312	
ALT	NONE	SHEET	3 OF 3

5204751

REVISONS		SIGNATURE AND DATE	
LT#	ZONE	DFTS	CHK
E	SEE SH1		

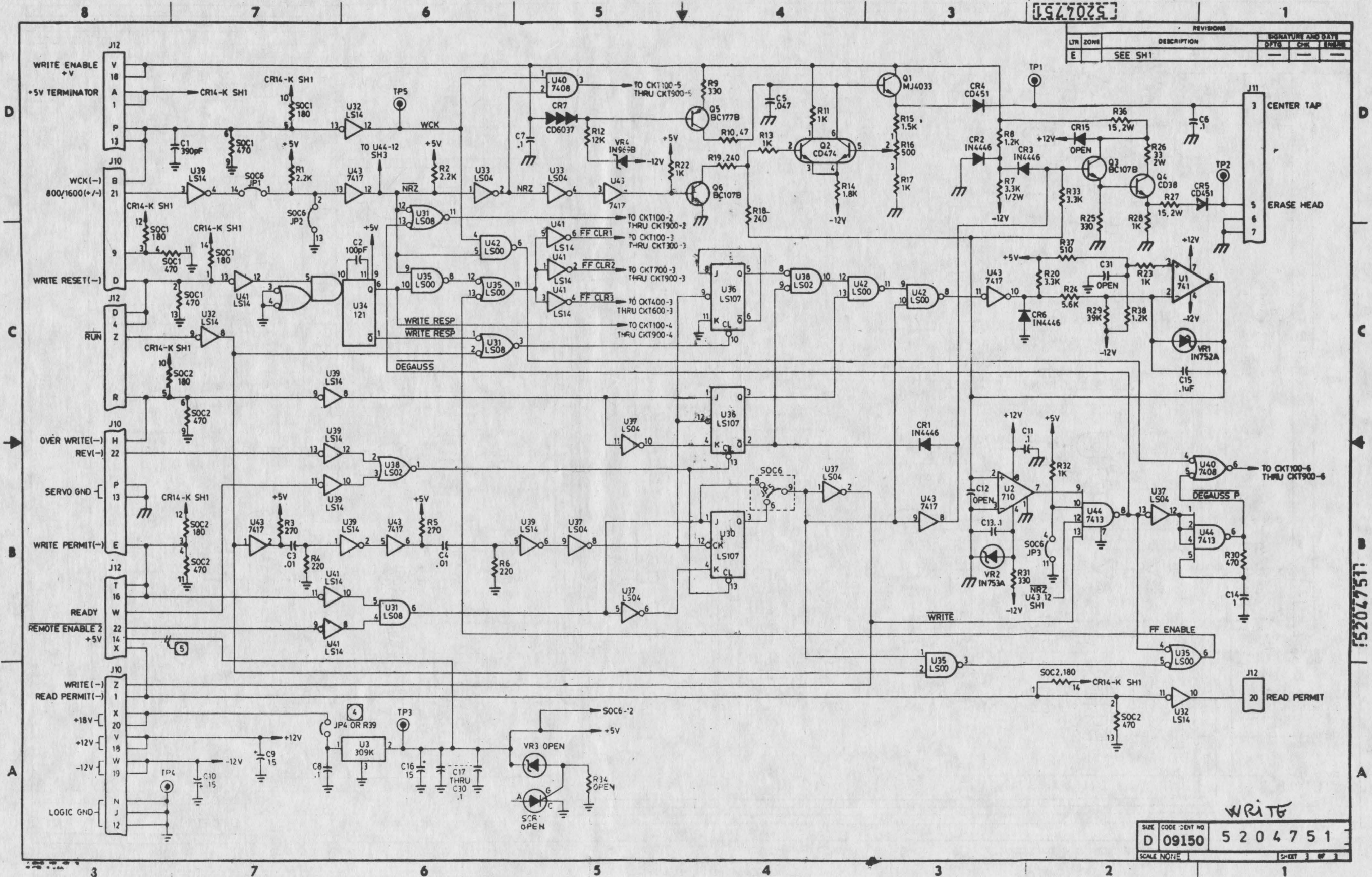

WRITE

SIZE	CODE	IDENT NO	5204751
D	09150		
SCALE NOTE		SHEET 3 OF 3	

5204751

REVISIONS			SIGNATURE AND DATE		
LTR	ZONE	DESCRIPTION	DFTG	CHK	ENG/DR
E		SEE SH 1			

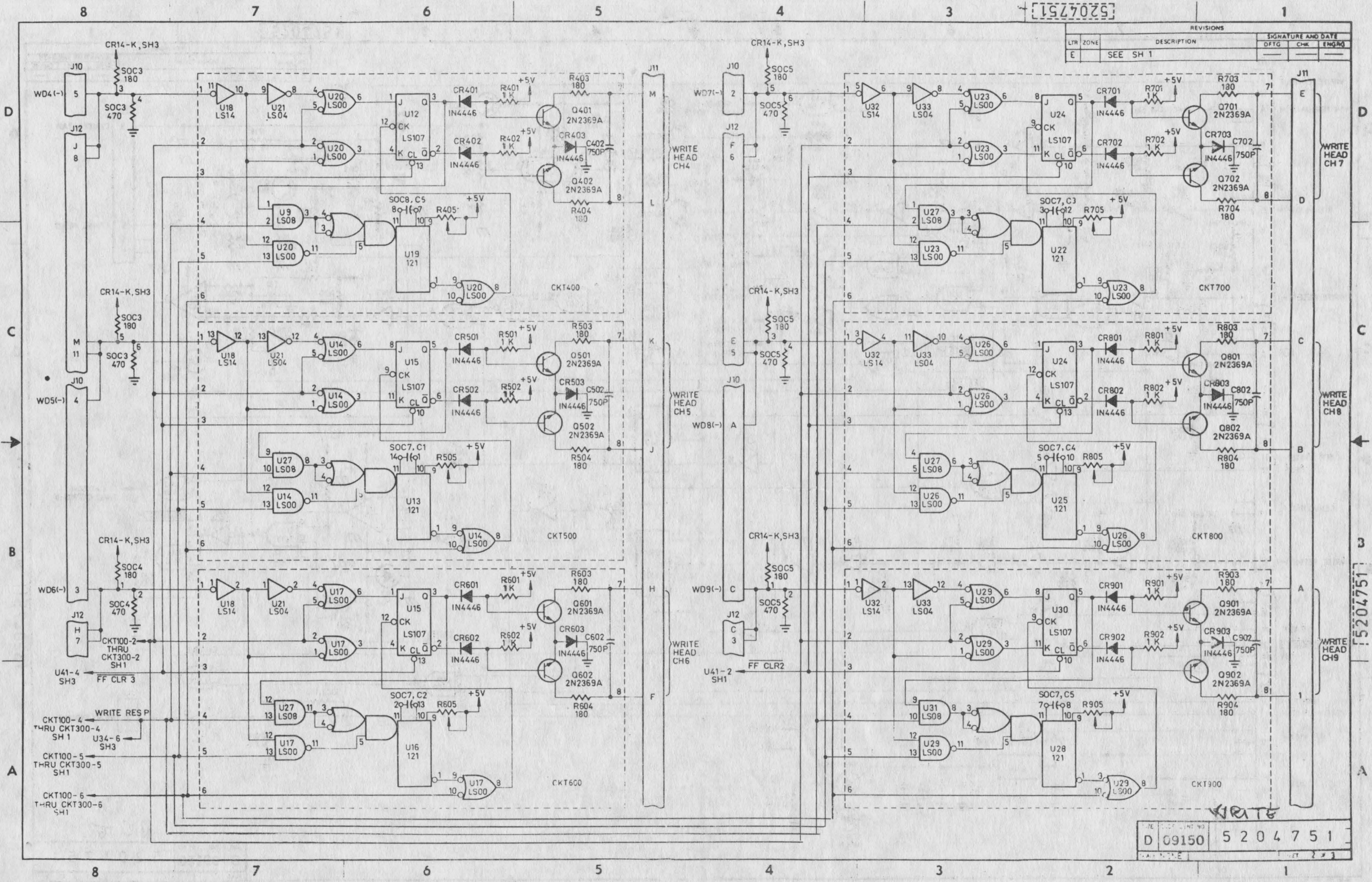

5204751

WRITE

D 09150 5204751

5204751

REVISIONS			SIGNATURE AND DATE		
LTR	ZONE	DESCRIPTION	DFTG	CHK	ENGRG
D		N:739			
		RE (DRAWN NO CHANGE)			
E		ANN2820-3			

LAST USED	DELETED	OPEN
VR4		VR3
CR15, 903	CR8, 9, 10, 11, 12, 13	CR15
Q6, 902		
R39, 905	R21, 35	R34
C32, 902	C101 THRU 901	C12, 31, 32
SOC8		
U44		
TP5		
JP5		
SCR1		SCR1
W1		

VERSION TABLE

TM 100 +/TME	ASSY P/N	DESCRIPTION
	5204750-01	JP4
	5204750-02	R39(6Ω, 9W, 5%)

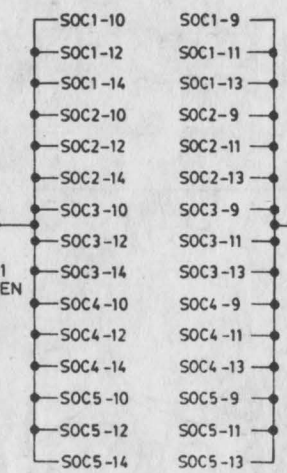
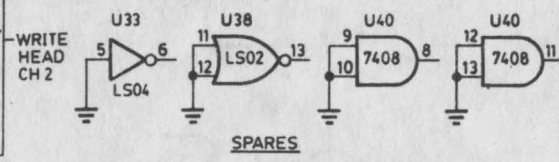

- SEE VERSION TABLE.
 - ALL CAPACITORS VALUES TO BE IN FARAD.
 - ALL RESISTORS VALUES TO BE IN OHM 1/4W 2%.
 - FOR B/M SEE 5204750.
- NOTES: UNLESS OTHERWISE SPECIFIED

<p>NOTICE</p> <p>THIS DRAWING SHALL NOT BE DUPLICATED, USED FOR ANY PURPOSE OTHER THAN THAT FOR WHICH PROVIDED OR DISCLOSED IN WHOLE OR IN PART, WITHOUT THE WRITTEN CONSENT OF AMPLEX CORPORATION. PROVIDED HOWEVER, THAT IF THIS DRAWING IS SPECIFIED TO BE DELIVERED TO THE GOVERNMENT, OR TO A GOVERNMENT CONTRACTOR, PURSUANT TO A GOVERNMENT CONTRACT, OR SUBCONTRACT, THE GOVERNMENT MAY MAKE SUCH USE OF THIS DRAWING AS IS AUTHORIZED BY THE APPLICABLE CONTRACT DOCUMENTS.</p>		<p>UNLESS OTHERWISE SPECIFIED</p> <p>DIMENSIONS ARE IN INCHES AND INCLUDE CHEMICALLY APPLIED OR PLATED FINISHES.</p> <p>TOL: 2 PL 3 PL ANLR</p> <p>REMOVE SHARP AND CHAMP EDGES OR RADIUS PER AND 10/87</p> <p>INTERPRET DRAWING PER ANSI Y14.5</p> <p>MATERIAL:</p> <p>FINISH:</p>		<p>SIGNATURE</p> <p>DATE</p> <p>DRAWN BY</p> <p>CHK BY</p> <p>DFTG</p> <p>ENGRG</p> <p>AUTH BY</p>		<p>AMPLEX</p> <p>MEMORY PRODUCTS DIVISION</p> <p>200 N. Main Street</p> <p>El Segundo, California 90245</p>	
<p>SCHMATIC WRITE ELEC</p> <p>PE/ NRZ</p>				<p>SIZE CODE IDENT NO</p> <p>D 09150-5204751</p>			
<p>SCALE NONE</p> <p>DO NOT SCALE THIS PRINT</p> <p>SHEET 1 OF 3</p>							

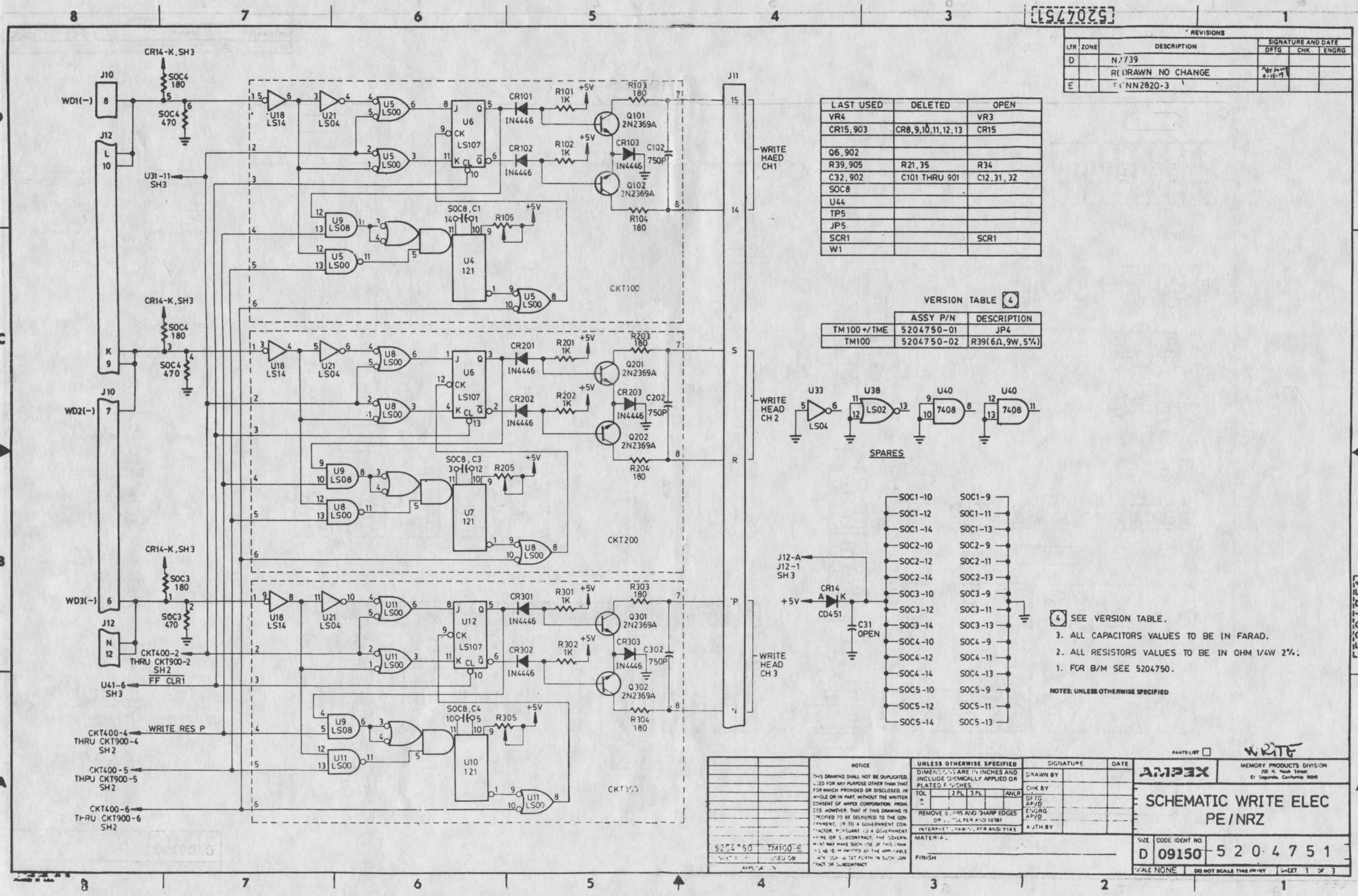

REVISIONS			SIGNATURE AND DATE		
LTR	ZONE	DESCRIPTION	DFTG	CHK	ENGRG
D		SEE SHEET 1			

5204753-01

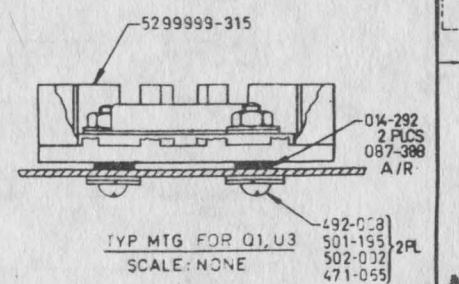
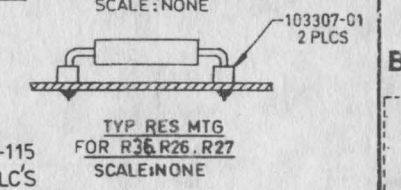
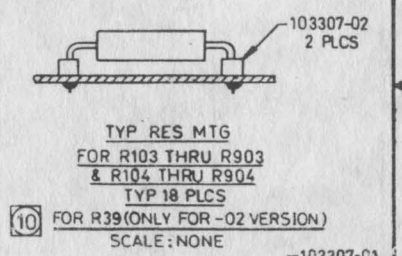
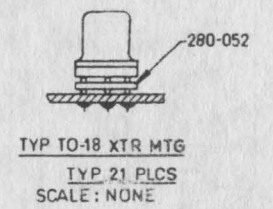
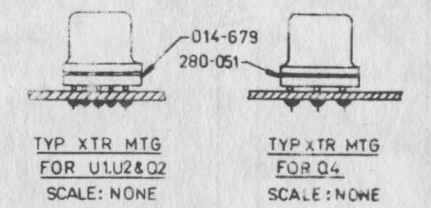
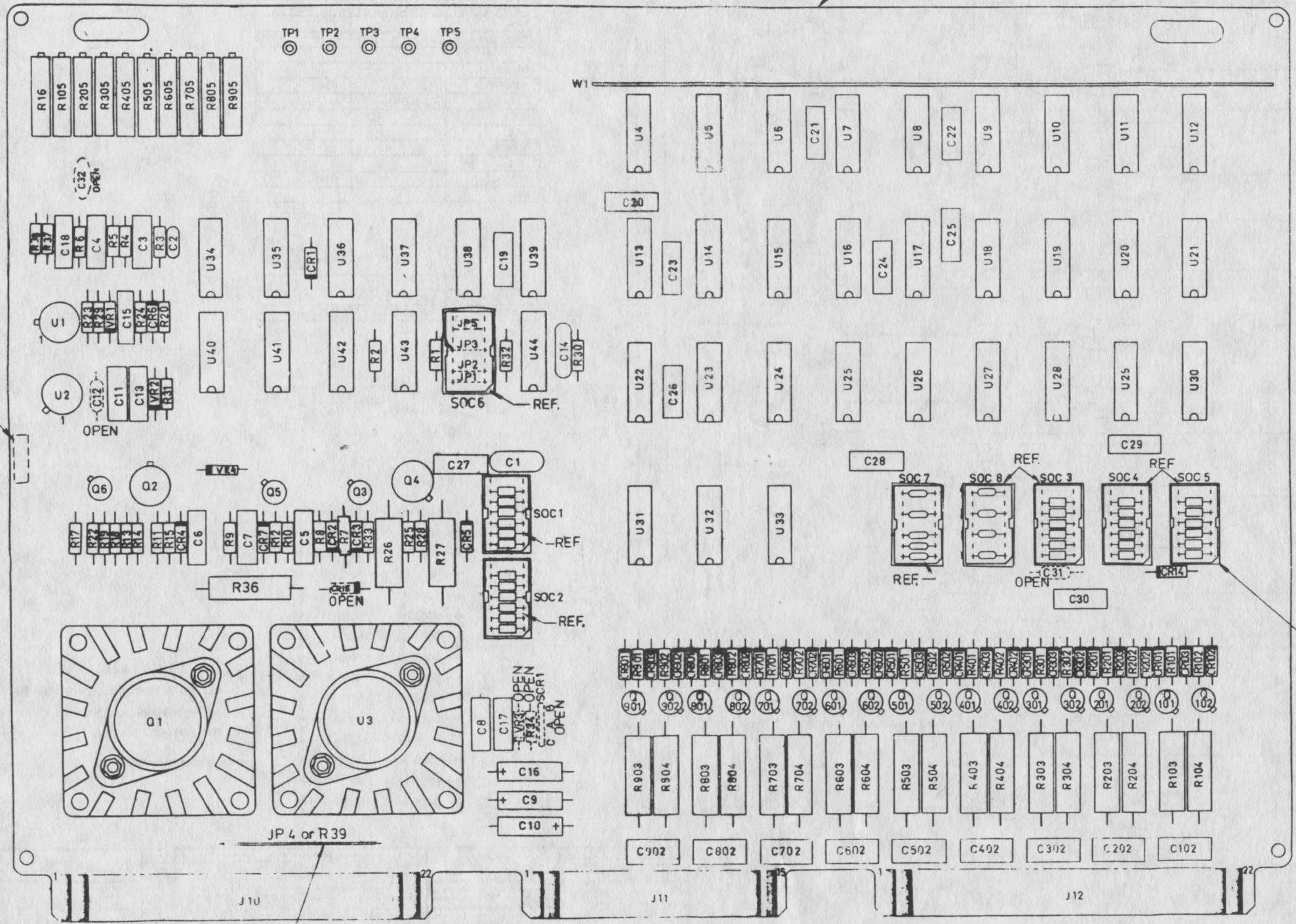

COMPONENT SIDE

WRITE

FILE	CODE	IDENT NO.	
D	09150	5204752	

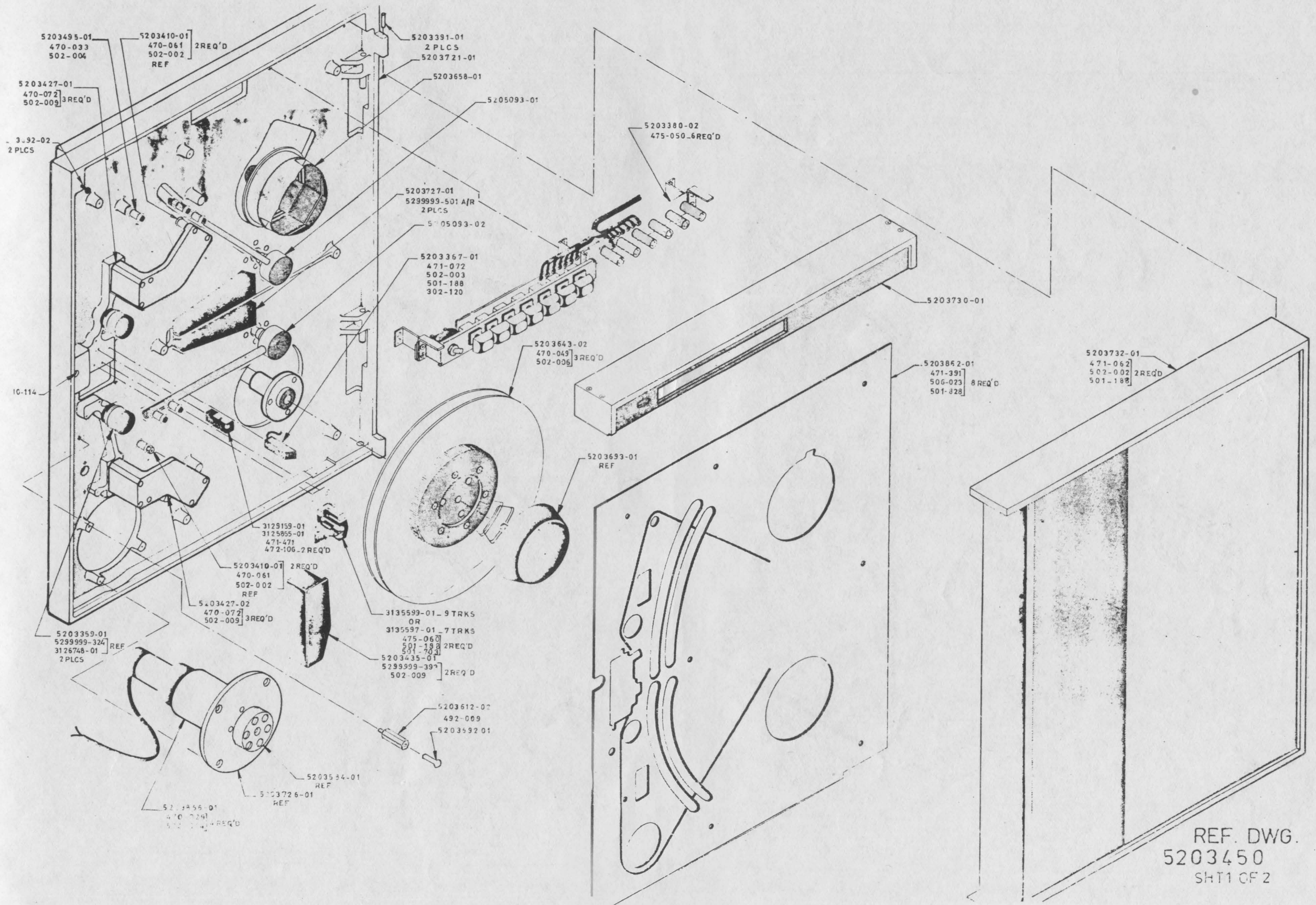

REF. DWG.
 5203450
 SHT1 OF 2

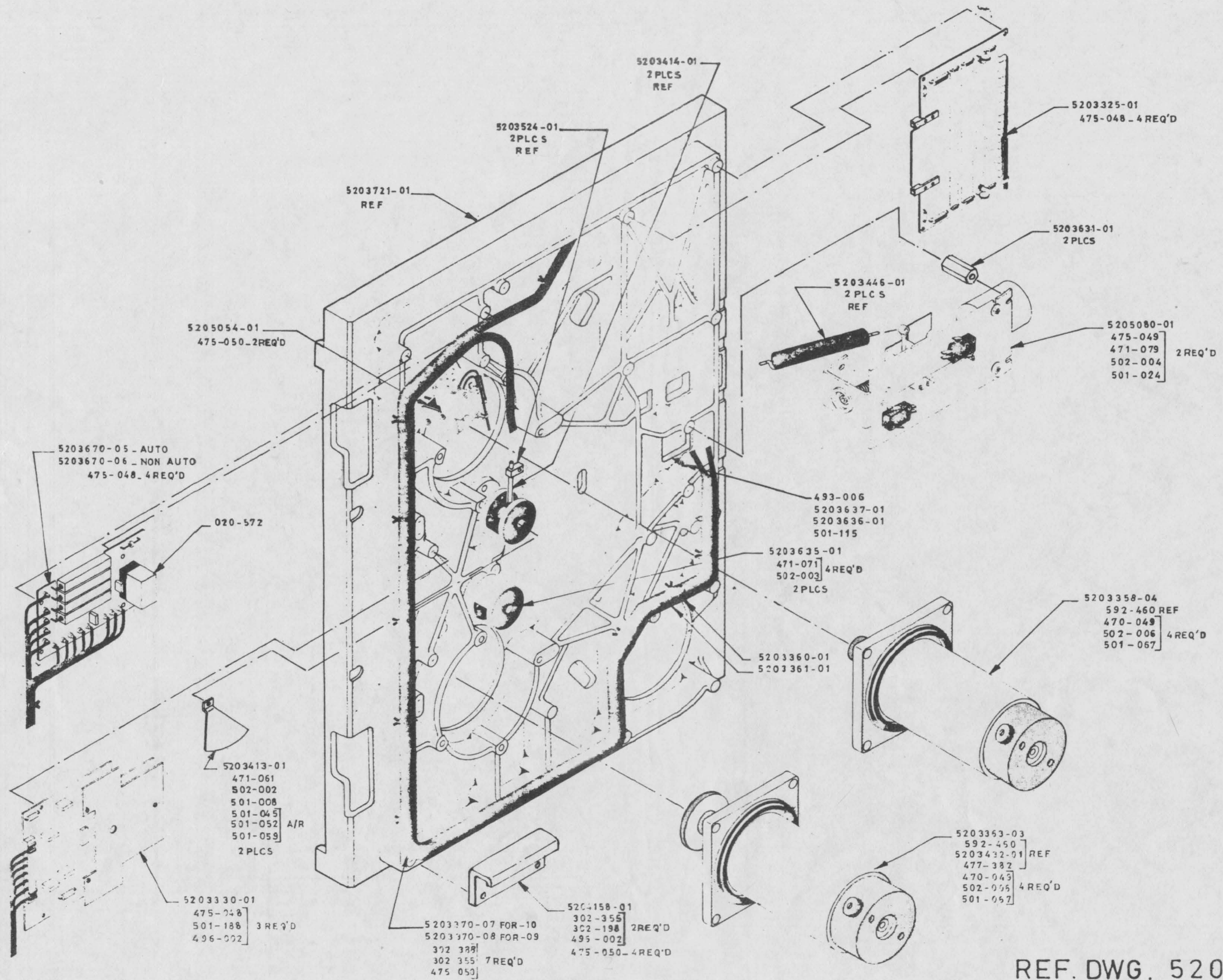

REF. DWG. 5203450

5205089

REV		DESCRIPTION	DATE
D	PROTO		
E	ERN N2621		
F	ECN N2733-2		
G	ECN N2763-2		
		REDRAWN NO CHANGE	

D
C
B
A

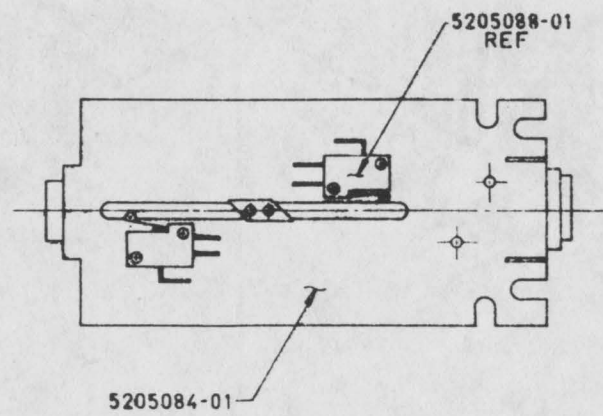
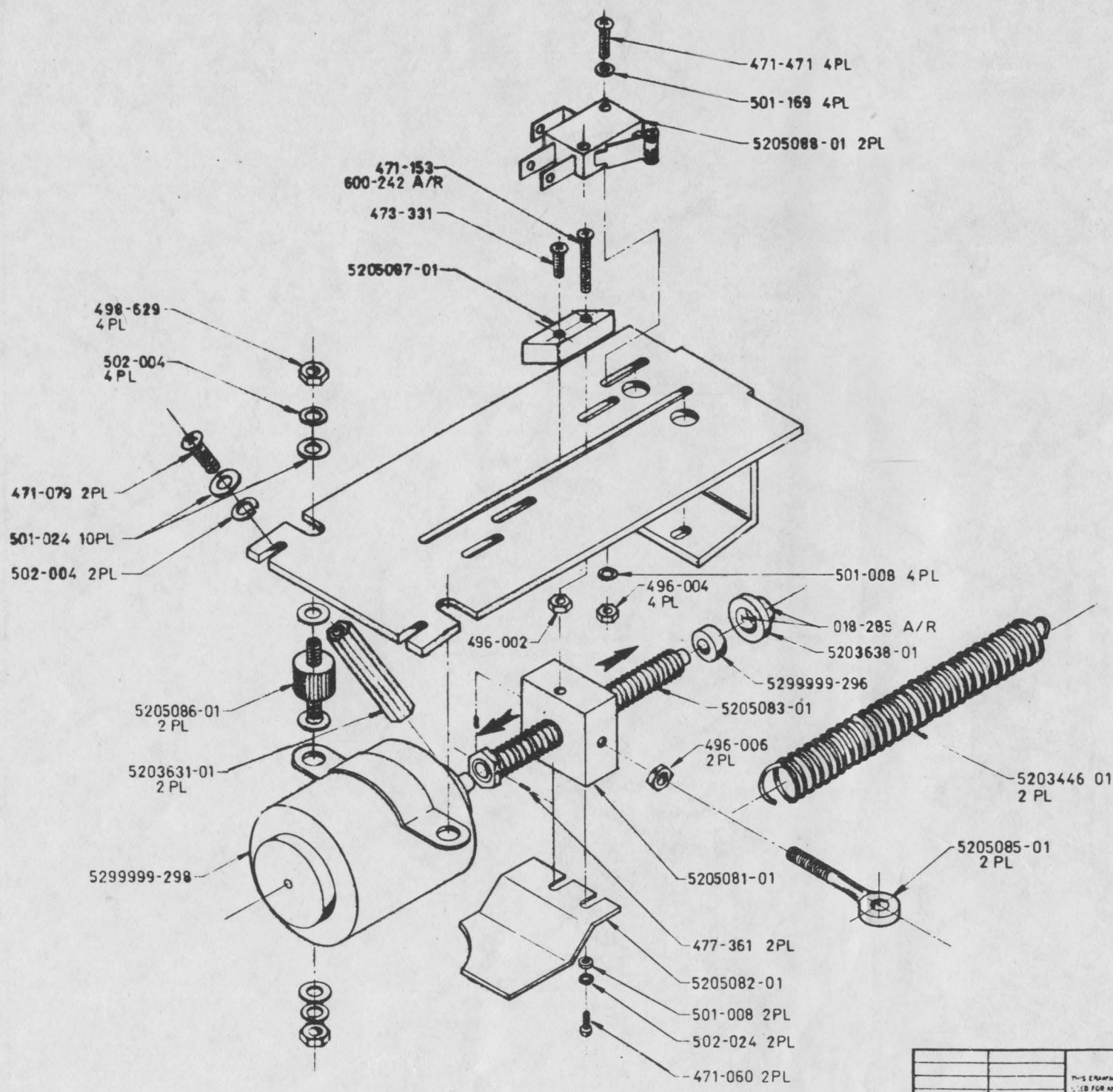

1. ASSEMBLE PER AMPLEX STDS.

NOTE: UNLESS OTHERWISE SPECIFIED

NOTICE		UNLESS OTHERWISE SPECIFIED		SIGNATURE		DATE		PART NO.		AMPLEX		AMP KRY PRODUCTS DIVISION 200 N. 100th Street St. Joseph, California 94580	
THIS DRAWING SHALL NOT BE USED FOR ANY PURPOSE OTHER THAN THAT FOR WHICH PROVIDED OR INDICATED IN THIS OR IN PART WITHOUT THE WRITTEN CONSENT OF AMPLEX CORPORATION. ANY OTHER USE OF THIS DRAWING IS PROHIBITED TO BE OBTAINED TO THE GOVERNMENT OR TO ANY OTHER PARTY WITHOUT THE WRITTEN CONSENT OF AMPLEX CORPORATION.		DIMENSIONS ARE IN INCHES AND INCLUDE DIMENSIONALLY APPLIED OR PLATED FINISHES.		DRAWN BY				5205089		LOAD SYSTEM ASSY. (REF. DWG)			
		REMOVE BURRS AND SHARP EDGES. DRILL TO PER AND TO DEPT.		CHECK BY				D		09150		5205089	
		MATERIAL		DATE				D		09150		5205089	
		FINISH											

8 7 6 5 4 3 2 1

5205089

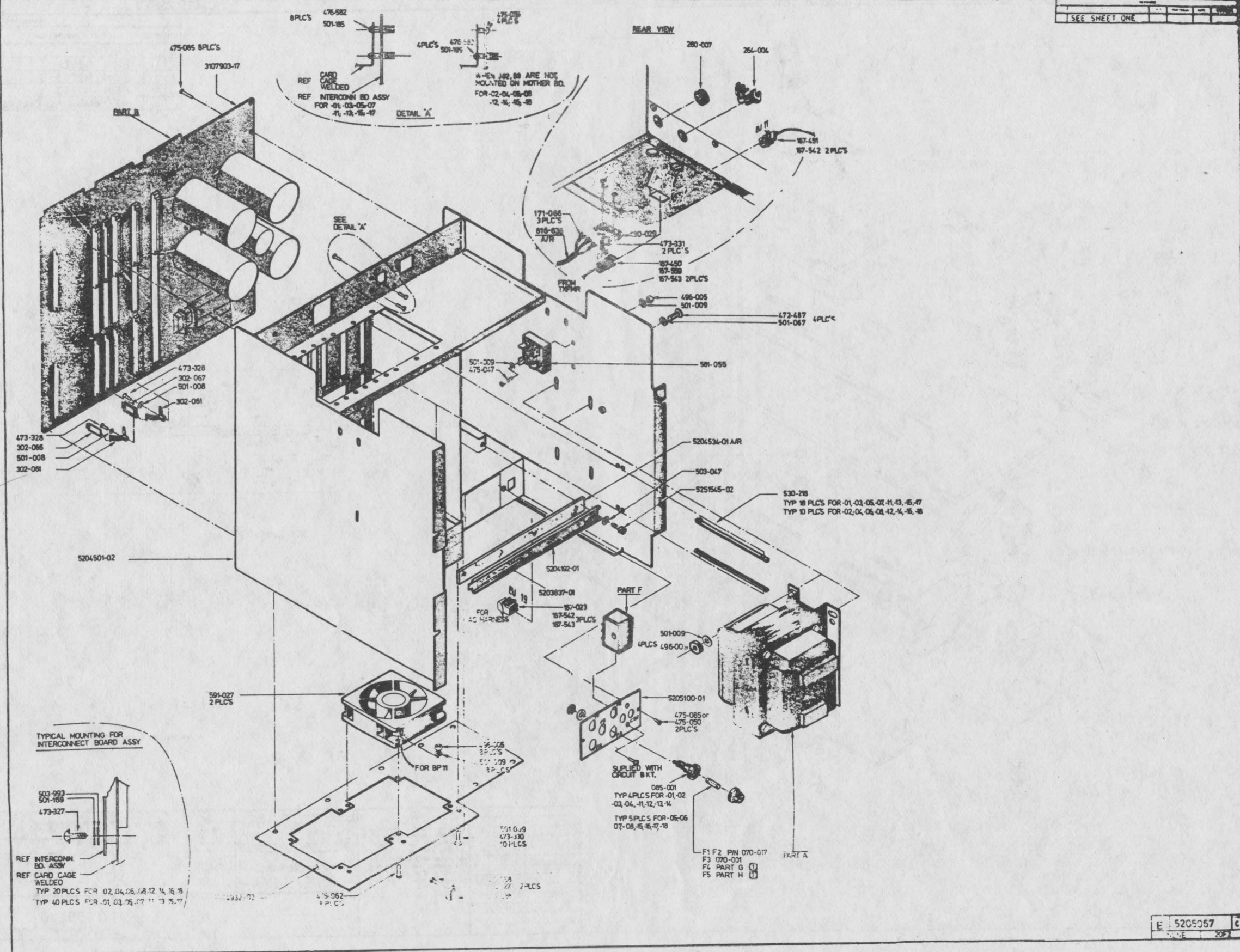

LAST USED	
R99	CR28,104,204
R124,224	Q26,106,206
TP6,101,201	JP2
C29,110,210	U10,101,201
VR5,101,201	SOC.1

NOT USED	DELETED
R16,38,44,45	
R104,204	
C107,207	
C3	
CR6,11,12,13,14,24,1	

INTEGRATED CIRCUIT LIST

AMPEX P/N	586-109	586-124	586-269	586-282	586-326	586-581	586-784	586-871	586-890
COM. P/N	SN 7402 N	JA 710 C	JA 741	MC 1439	SN 7404 N	SN 7403 N	SN 7438 N	SN 7413 N	SN 7417 N
REF. DES.	U5	U3, U4	U1, U2	U101, U201	U8	U7	U6	U9	U10

...	DESCRIPTION	DATE	DRAWN BY	DATE	APPROVED BY
A	ECN N 1978/N2026	08-08-78	HG		
B	ECN N 2144	08-08-78	HG		
C	ECN N 2201	01-04-78	HG		
D	ECN N 2204	21-04-78	HG		
E	ECN N 2205	1-9-78	HG		
F	ECN N 2214	3-2-78	HG		
G	ECN N 2218	02-02-78	HG		
H	ECN N 2292	05-1-78	HG		
J	ECN N 2497	13-04-78	HG		
K	ECN N 2610	7-10-78	HG		
L	ECN N 2714.12	11-01-78	HG		
M	ECN N 2751-2	08-04-78	HG		

VERSION TABLE (14)

P/N	COMPONENT DESIG.				
	C14	JP1	C8	R27	R13
5203820-10	47µF,20V	OPEN	OPEN	OPEN	360K
5203820-20	OPEN	OPEN	OPEN	OPEN	360K
5203820-11	47µF,20V	OPEN	OPEN	OPEN	680K
5203820-21	OPEN	OPEN	OPEN	OPEN	680K

DASH NO.	FUNCTION
-21	NON AUTO 12.5 IPS
-11	AUTO 12.5 IPS
-20	NON AUTO > 12.5 IPS
-10	AUTO > 12.5 IPS

- 18 JP2 TO BE 614-762
- 17 FOR PCBA R.DWG. SEE 5203822
- 16 FOR B/M SEE 5203820
- 15 THIS SCHEMATIC MUST BE USED WITH SCHEMATIC 5203541.
- 14 SEE VERSION TABLE.
- 13 Q19 IS 014-597.
- 12 Q13 IS 014-247.
- 11 Q25 IS 5299999-325.
- 10 Q4,6,8,10,12,15 THRU 18,20,21,101,103,201,203,1,2,14,26,11 ARE 5299999-257.
- 9 Q3,5,7,9, 102,104,202,204 ARE 5299999-256.
- 8 Q22,105,205 ARE 580-466.
- 7 Q23,24,106,206 ARE 580-465.
- 6 ~~VR5 IS 013-224~~
- 5 VR4,5,101,201 ARE 013-358; VR1,2 ARE 581-457.
- 4 VR3 IS 013-257.
- 3 ALL DIODES ARE 581-157 EXCEPT CR102,103,202,203 ARE 013-188.
- 2 ALL CAPACITOR VALUES ARE IN µF, 100V.
- 1 ALL RESISTOR VALUES ARE IN OHMS 1/4W, 2%.

NOTES: UNLESS OTHERWISE SPECIFIED.

DO NOT SCALE DRAWING UNLESS OTHERWISE SPECIFIED		AMPEX	
5203821		SCHEMATIC SERVO BOARD	
5203822		C 5203821 M	
		NONE 1 OF 2	

SIGNATURE AND DATE	
DFTG	CHK ENGRG

10 VERSION TABLE

P/N	IPS	BPI	STROBED	REVDESKEW	R38	JP1	JP2	JP3	R42.43	R44.45	R120 THRU R920	CR6,7,102 THRU CR902	Q8,09	R5	R5	C102,104,108,110 113 THRU C902, 904,908,910,913	C106,112,115 THRU C906,912,916	C34	R41	
5203310-01	45/50	556-800	YES	YES	8.2K	YES	OPEN	NO	1.8K	5.1K	10K,1W	581-157	014-364	180	47D	620PF,300V,5%	820PF,300V,5%	2700PF,500V,5%	10K,1W	
5203310-02	45/50	200-800	YES	YES	22K	YES	OPEN	NO	1.8K	5.1K	10K,1W	581-157	014-364	180	47D	620PF,300V,5%	820PF,300V,5%	2700PF,500V,5%	10K,1W	
5203310-03	45/50	556-800	NO	YES	8.2K	OPEN	YES	NO	1.8K	5.1K	10K,1W	581-157	014-364	5.1K	OPEN	620PF,300V,5%	820PF,300V,5%	2700PF,500V,5%	10K,1W	
5203310-04	45/50	200-800	NO	YES	22K	OPEN	YES	NO	1.8K	5.1K	10K,1W	581-157	014-364	5.1K	OPEN	620PF,300V,5%	820PF,300V,5%	2700PF,500V,5%	10K,1W	
5203310-05	45/50	556-800	YES	NO	8.2K	YES	OPEN	YES	OPEN	OPEN	OPEN	OPEN	OPEN	180	47D	620PF,300V,5%	820PF,300V,5%	2700PF,500V,5%	10K,1W	
5203310-06	45/50	200-800	YES	NO	22K	YES	OPEN	YES	OPEN	OPEN	OPEN	OPEN	OPEN	180	47D	620PF,300V,5%	820PF,300V,5%	2700PF,500V,5%	10K,1W	
5203310-07	45/50	556-800	NO	NO	8.2K	OPEN	YES	YES	OPEN	OPEN	OPEN	OPEN	OPEN	5.1K	OPEN	620PF,300V,5%	820PF,300V,5%	2700PF,500V,5%	10K,1W	
5203310-08	45/50	200-800	NO	NO	22K	OPEN	YES	YES	OPEN	OPEN	OPEN	OPEN	OPEN	5.1K	OPEN	620PF,300V,5%	820PF,300V,5%	2700PF,500V,5%	10K,1W	
5203310-09	45/50	800-800	NO	NO	1.8K	OPEN	YES	YES	OPEN	OPEN	OPEN	OPEN	OPEN	5.1K	OPEN	620PF,300V,5%	820PF,300V,5%	2700PF,500V,5%	OPEN	
5203310-10	45/50	800-800	NO	YES	1.8K	OPEN	YES	NO	1.8K	5.1K	10K,1W	581-157	014-364	5.1K	OPEN	620PF,300V,5%	820PF,300V,5%	2700PF,500V,5%	OPEN	
5203310-11	37.5	556-800	YES	YES	8.2K	YES	OPEN	NO	1.8K	5.1K	10K,1W	581-157	014-364	180	47D	750PF,300V,5%	1000PF,100V,5%	3300PF,300V,5%	10K,1W	
5203310-12	37.5	200-800	YES	YES	22K	YES	OPEN	NO	1.8K	5.1K	10K,1W	581-157	014-364	180	47D	750PF,300V,5%	1000PF,100V,5%	3300PF,300V,5%	10K,1W	
5203310-13	37.5	556-800	NO	YES	8.2K	OPEN	YES	NO	1.8K	5.1K	10K,1W	581-157	014-364	5.1K	OPEN	750PF,300V,5%	1000PF,100V,5%	3300PF,300V,5%	10K,1W	
5203310-14	37.5	200-800	NO	YES	22K	OPEN	YES	NO	1.8K	5.1K	10K,1W	581-157	014-364	5.1K	OPEN	750PF,300V,5%	1000PF,100V,5%	3300PF,300V,5%	10K,1W	
5203310-15	37.5	556-800	YES	NO	8.2K	YES	OPEN	YES	OPEN	OPEN	OPEN	OPEN	OPEN	180	47D	750PF,300V,5%	1000PF,100V,5%	3300PF,300V,5%	10K,1W	
5203310-16	37.5	200-800	YES	NO	22K	YES	OPEN	YES	OPEN	OPEN	OPEN	OPEN	OPEN	180	47D	750PF,300V,5%	1000PF,100V,5%	3300PF,300V,5%	10K,1W	
5203310-17	37.5	556-800	NO	NO	8.2K	OPEN	YES	YES	OPEN	OPEN	OPEN	OPEN	OPEN	5.1K	OPEN	750PF,300V,5%	1000PF,100V,5%	3300PF,300V,5%	10K,1W	
5203310-18	37.5	200-800	NO	NO	22K	OPEN	YES	YES	OPEN	OPEN	OPEN	OPEN	OPEN	5.1K	OPEN	750PF,300V,5%	1000PF,100V,5%	3300PF,300V,5%	10K,1W	
5203310-19	37.5	800-800	NO	NO	1.8K	OPEN	YES	YES	OPEN	OPEN	OPEN	OPEN	OPEN	5.1K	OPEN	750PF,300V,5%	1000PF,100V,5%	3300PF,300V,5%	OPEN	
5203310-20	37.5	800-800	NO	YES	1.8K	OPEN	YES	NO	1.8K	5.1K	10K,1W	581-157	014-364	5.1K	OPEN	750PF,300V,5%	1000PF,100V,5%	3300PF,300V,5%	OPEN	
5203310-21	24-25	556-800	YES	YES	8.2K	YES	OPEN	NO	1.8K	5.1K	10K,1W	581-157	014-364	180	47D	1100PF,500V,5%	1500PF,500V,5%	4700PF,300V,5%	10K,1W	
5203310-22	24-25	200-800	YES	YES	22K	YES	OPEN	NO	1.8K	5.1K	10K,1W	581-157	014-364	180	47D	1100PF,500V,5%	1500PF,500V,5%	4700PF,300V,5%	10K,1W	
5203310-23	24-25	556-800	NO	YES	8.2K	OPEN	YES	NO	1.8K	5.1K	10K,1W	581-157	014-364	5.1K	OPEN	1100PF,500V,5%	1500PF,500V,5%	4700PF,300V,5%	10K,1W	
5203310-24	24-25	200-800	NO	YES	22K	OPEN	YES	NO	1.8K	5.1K	10K,1W	581-157	014-364	5.1K	OPEN	1100PF,500V,5%	1500PF,500V,5%	4700PF,300V,5%	10K,1W	
5203310-25	24-25	556-800	YES	NO	8.2K	YES	OPEN	YES	OPEN	OPEN	OPEN	OPEN	OPEN	180	47D	1100PF,500V,5%	1500PF,500V,5%	4700PF,300V,5%	10K,1W	
5203310-26	24-25	200-800	YES	NO	22K	YES	OPEN	YES	OPEN	OPEN	OPEN	OPEN	OPEN	180	47D	1100PF,500V,5%	1500PF,500V,5%	4700PF,300V,5%	10K,1W	
5203310-27	24-25	556-800	NO	NO	8.2K	OPEN	YES	YES	OPEN	OPEN	OPEN	OPEN	OPEN	5.1K	OPEN	1100PF,500V,5%	1500PF,500V,5%	4700PF,300V,5%	10K,1W	
5203310-28	24-25	200-800	NO	NO	22K	OPEN	YES	YES	OPEN	OPEN	OPEN	OPEN	OPEN	5.1K	OPEN	1100PF,500V,5%	1500PF,500V,5%	4700PF,300V,5%	10K,1W	
5203310-29	24-25	800-800	NO	NO	1.8K	OPEN	YES	YES	OPEN	OPEN	OPEN	OPEN	OPEN	5.1K	OPEN	1100PF,500V,5%	1500PF,500V,5%	4700PF,300V,5%	OPEN	
5203310-30	24-25	800-800	NO	YES	1.8K	OPEN	YES	NO	1.8K	5.1K	10K,1W	581-157	014-364	5.1K	OPEN	1100PF,500V,5%	1500PF,500V,5%	4700PF,300V,5%	OPEN	
5203310-99					OPEN	OPEN	OPEN	OPEN	OPEN	OPEN	OPEN	OPEN	OPEN	OPEN	OPEN	OPEN	OPEN	OPEN	OPEN	OPEN
5203310-34	12.5	200-800	NO	YES	22K	OPEN	YES	NO	1.8K	5.1K	10K,1W	581-157	014-364	5.1K	OPEN	2200PF,500V,5%	3300PF,300V,5%	.01uF,250V,10%	10K,1W	
5203310-35	12.5	556-800	YES	NO	8.2K	YES	OPEN	YES	OPEN	OPEN	OPEN	OPEN	OPEN	180	47D	2200PF,500V,5%	3300PF,300V,5%	.01uF,250V,10%	10K,1W	
5203310-32	12.5	200-800	YES	YES	22K	YES	OPEN	NO	1.8K	5.1K	10K,1W	581-157	014-364	180	47D	2200PF,500V,5%	3300PF,300V,5%	.01uF,250V,10%	10K,1W	
5203310-37	12.5	556-800	NO	NO	8.2K	OPEN	YES	YES	OPEN	OPEN	OPEN	OPEN	OPEN	5.1K	OPEN	2200PF,500V,5%	3300PF,300V,5%	.01uF,250V,10%	10K,1W	
5203310-38	12.5	200-800	NO	NO	22K	OPEN	YES	YES	OPEN	OPEN	OPEN	OPEN	OPEN	5.1K	OPEN	2200PF,500V,5%	3300PF,300V,5%	.01uF,250V,10%	10K,1W	
5203310-39	12.5	800-800	NO	NO	1.8K	OPEN	YES	YES	OPEN	OPEN	OPEN	OPEN	OPEN	5.1K	OPEN	2200PF,500V,5%	3300PF,300V,5%	.01uF,250V,10%	OPEN	

NOTICE		DIMENSIONS ARE IN INCHES AND INCLUDE CHEMICALLY APPLIED OR PLATED FINISHES		SIGNATURE		DATE		PARTS LIST		COMPUTER PRODUCTS DIVISION Marina del Rey, California 90291	
THIS DRAWING SHALL NOT BE DUPLICATED, REPRODUCED OR USED FOR ANY PURPOSE OTHER THAN THAT FOR WHICH PROVIDED OR DISCLOSED, IN WHOLE OR IN PART, WITHOUT THE WRITTEN CONSENT OF AMPLEX CORPORATION. PROVIDED, HOWEVER, THAT IF THIS DRAWING IS SPECIFIED TO BE DELIVERED TO THE GOVERNMENT, OR TO A GOVERNMENT CONTRACTOR, PURSUANT TO A GOVERNMENT CONTRACT, THE GOVERNMENT MAY HAVE SUCH USE OF THIS DRAWING AS IS PERMITTED BY THE APPLICABLE DATA CLASSIFICATION IN SUCH CONTRACT OR SUBCONTRACT.		REMAIN SQUARE AND SHARP EDGES PER MIL-T-20 (REV. 10-68)		DRAWN BY: [Signature]		[Date]		AMPEX		SCHEMATIC READ ELECTRONICS TM100	
5203310		TM100		CHK BY: [Signature]		[Date]		DFTG		SIZE CODE IDENT NO	
NEXT ASSY USED ON		APPLICATION		AUTH BY:		[Date]		ENGRG		D 09150 5203311	
								APVD		SCALE DO NOT SCALE THIS PRINT SHEET 1 OF 3	

REVISIONS			SIGNATURE AND DATE		
LTR	ZONE	DESCRIPTION	DFTG	CHK	DATE
..		SEE SHEET ONE			

10 VERSION TABLE

P/N	IPS	BPI	STROBED	REVDESKEW	R38	JP1	JP2	JP3	R42,43	R44,45	R120 THRU R920	CR6.7.102 THRU CR902	Q8, Q9	R5	R6	C102,104,108,110,113 THRU C902,904,908,910,913	C106,112,116 THRU C906,912,916	C34	R41
5203310-40	12.5	800-800	NO	YES	1.8K	OPEN	YES	NO	1.8K	5.1K	10K, 1W	581-157	014-364	5.1K	OPEN	2200PF, 500V, 5%	3300PF, 300V, 5%	.01μF, 250V, 10%	OPEN
5203310-63	75	556-800	NO	YES	8.2K	OPEN	YES	NO	1.8K	5.1K	10K, 1W	581-157	014-364	5.1K	OPEN	390PF, 500V, 5%	500PF, 500V, 5%	1500PF, 500V, 5%	10K, 1W
5203310-64	75	200-800	NO	YES	22K	OPEN	YES	NO	1.8K	5.1K	10K, 1W	581-157	014-364	5.1K	OPEN	390PF, 500V, 5%	500PF, 500V, 5%	1500PF, 500V, 5%	10K, 1W
5203310-67	75	556-800	NO	NO	8.2K	OPEN	YES	YES	OPEN	OPEN	OPEN	OPEN	OPEN	5.1K	OPEN	390PF, 500V, 5%	500PF, 500V, 5%	1500PF, 500V, 5%	10K, 1W
5203310-68	75	200-800	NO	NO	22K	OPEN	YES	YES	OPEN	OPEN	OPEN	OPEN	OPEN	5.1K	OPEN	390PF, 500V, 5%	500PF, 500V, 5%	1500PF, 500V, 5%	10K, 1W
5203310-69	75	800-800	NO	NO	1.8K	OPEN	YES	YES	OPEN	OPEN	OPEN	OPEN	OPEN	5.1K	OPEN	390PF, 500V, 5%	500PF, 500V, 5%	1500PF, 500V, 5%	OPEN
5203310-70	75	800-800	NO	YES	1.8K	OPEN	YES	NO	1.8K	5.1K	10K, 1W	581-157	014-364	5.1K	OPEN	390PF, 500V, 5%	500PF, 500V, 5%	1500PF, 500V, 5%	OPEN

INTEGRATED CIRCUIT LIST

AMPEX P/N	586-075	586-124	586-326	586-411	586-533	586-756	586-784	586-647
COM P/N	SN7400N	μA710C	SN7404N	MC1805P	SN74121N	LM 309K	SN7438N	SN74107N
REF DES	U3, U105 THRU U905	U101,102,103 THRU U901,902,903	U1, U2	U4	U6, U104 THRU U904	U14	U5, 9,13	U7, 8,10, 11,12
GRD PIN	7	1	7	7	7	3	7	7
VCC PIN	14	8,4	14	14	14	2	14	14

LAST USED	DELETED
R50,122 THRU 922	
C42,117 THRU 917	C1,2,40
CR8,102 THRU 902	
TP6,102 THRU 902	101 THRU 901
U14,105 THRU 905	
Q9,102 THRU 902	
VR1	
JP3	

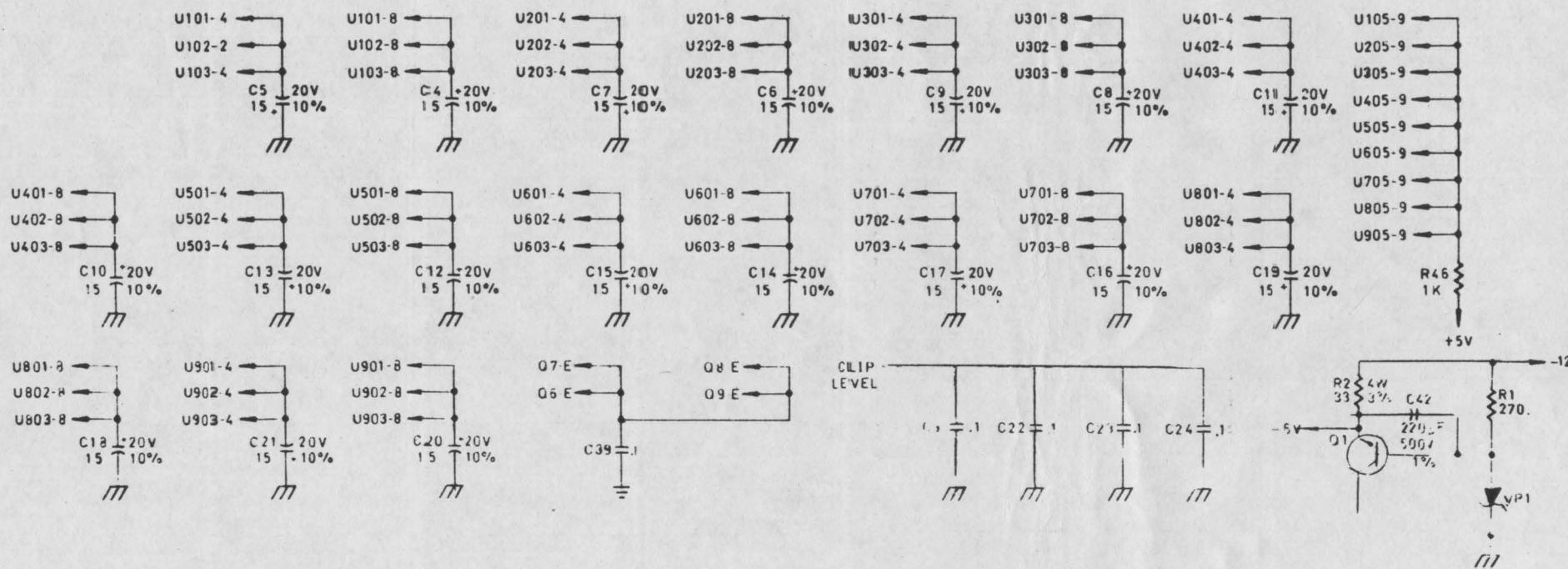
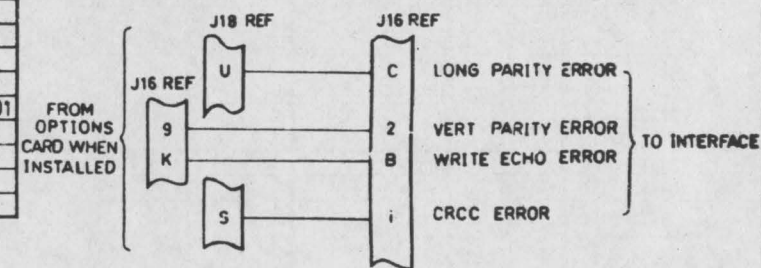

- 10 SEE VERSION TABLE.
- ALL JUMPERS ARE 614-762.
 - Q4, Q5 ARE 014-505.
 - Q6, Q7 ARE 014-364.
 - Q2, Q3, Q101, Q102 THRU Q901, Q902 ARE 014-248.
 - Q1 IS 014-247.
 - VR1 IS 013-983.
 - ALL DIODE ARE 581-157.
 - ALL CAPACITOR VALUES ARE IN MICROFARADS 30V±80% -20%.
 - ALL RESISTOR VALUES ARE IN OHMS, 1/4W, ±2%.
- NOTES: UNLESS OTHERWISE SPECIFIED

REVISIONS			
LTR	ZONE	DESCRIPTION	SIGNATURE AND DATE
N		ECN N 2507	
P		ECN N 2549 1	
R		ECN N 2711 1	
S		ECN N 2752	

4 VERSION TABLE 1

	45 IPS	45-50 IPS	37.5 IPS	37.5 IPS	25 IPS	25 IPS H/P	12.5 IPS	18.75 IPS		COMMON
	-01	-05	-11	-15	-21	-25	-31	-41		-99
R107 THRU 907	100Ω	100Ω	100Ω	100Ω	82 Ω	82Ω	150Ω	120Ω		OPEN
R10	18K	18K	27K	27K	39K	39K	39K	47K		OPEN
R113 THRU 913	2K	2K	2K	2K	2K	2K	2K	2K		OPEN
R115 THRU 915	22K	22K	27K	27K	27K	27K	22K	33K		OPEN
R116 THRU 916	22K	13K	27K	27K	27K	18K	22K	33K		OPEN
R114 THRU 914	27K	27K	22K	22K	22K	22K	22 K	22K		OPEN
C101 THRU 901	220pF	220pF	300pF	300pF	390pF	390pF	680pF	500pF		OPEN
C109 THRU 909	560pF	560pF	390pF	390pF	820pF	820pF	1500pF	1500pF		OPEN
C104 THRU 904	.1μF	.033μF	.1μF	.022μF	.1μF	.1μF	.1μF	.1μF		OPEN
C1 THRU 9	.010μF	.010μF	.015μF	.015μF	.022μF	.022μF	.047μF	.033μF		OPEN
C107 THRU 907	33pF	33pF	47pF	47pF	82pF	82pF	620pF	100pF		OPEN
C106 THRU 906	JUMP	JUMP	JUMP	JUMP	JUMP	JUMP	JUMP	JUMP		OPEN
C111 THRU 911	33pF	33pF	47pF	47pF	82pF	82pF	100pF	100pF		OPEN
R41	OPEN	OPEN	OPEN	OPEN	OPEN	OPEN	OPEN	OPEN		OPEN
R42	OPEN	OPEN	OPEN	OPEN	OPEN	OPEN	OPEN	OPEN		OPEN
R43	OPEN	OPEN	OPEN	OPEN	OPEN	OPEN	OPEN	OPEN		OPEN
R44	OPEN	OPEN	OPEN	OPEN	OPEN	OPEN	OPEN	OPEN		OPEN
R53	OPEN	OPEN	OPEN	OPEN	OPEN	OPEN	OPEN	OPEN		OPEN
R111 THRU 911	OPEN	OPEN	OPEN	OPEN	OPEN	OPEN	OPEN	OPEN		OPEN
CR12	OPEN	OPEN	OPEN	OPEN	OPEN	OPEN	OPEN	OPEN		OPEN
Q1	OPEN	OPEN	OPEN	OPEN	OPEN	OPEN	OPEN	OPEN		OPEN
Q2	OPEN	OPEN	OPEN	OPEN	OPEN	OPEN	OPEN	OPEN		OPEN
Q103 THRU 903	OPEN	OPEN	OPEN	OPEN	OPEN	OPEN	OPEN	OPEN		OPEN

- 9 FOR -31 ONLY:
R114 THRU R914 (RES 22K) BECOME C109 THRU C909 (CAP 1500pF); C109 THRU C909 (CAP 1500pF) BECOME R114 THRU R914 (RES 22K).
8. FOR ASSY REF DWG SEE 5203517.
7. ALL RESISTOR VALUES ARE IN OHMS, 1/4W, 2%.
6. ALL CAPACITOR VALUES ARE IN MICROFARADS, 100V.
- 5 FOR I.C. SEE TABLE 2.
- 4 SEE VERSION TABLE 1.
3. Q1 IS OPEN.
Q2 IS OPEN.
Q3 IS 014-248.
Q4 IS 014-247.
Q101,102,104-Q901,902,904 ARE 5299999-415.
2. CR11 IS 013-188.
CR12 IS OPEN.
CR10 IS 013-599.
1. VR1 IS 013-983.

5 INTEGRATED CIRCUIT TABLE 2

AMPEX P/N	586-075	586-109	586-549	586-581	586-756	586-784	586-797	587-478	587-249
COMMERCIAL P/N	SN7400N	SN7402N	LM1414	SN7403N	LM309K	SN7438N	SN74123N	LM318H	SN7409N
REF. DES.	U8,10,12,14,16	U6	U102 THRU 902	U7,18	U22	U19,20,21	U1 THRU 5	U101 THRU 901	U9,11,13,15,17
VOLTAGE PIN	14	14	3,10(+12V)7,14(-6V)	14	2	14	16	7(+12V) 4(-12V)	14
GROUND PIN	7	7	11	7	CASE	7	8		7

C117 THRU 917	OPEN
JP1 THRU 10	OPEN

<small>NOTICE</small> THIS DRAWING IS THE PROPERTY OF AMPEX CORPORATION. IT IS TO BE USED ONLY FOR THE PURPOSES SPECIFIED HEREIN. IT IS TO BE RETURNED TO AMPEX CORPORATION UPON REQUEST. IT IS TO BE DESTROYED UPON THE EXPIRATION OF THE PATENT RIGHTS COVERED BY THIS DRAWING. IT IS TO BE KEPT IN A SAFE PLACE AND NOT TO BE LOANED, REPRODUCED, COPIED, OR IN ANY MANNER DISSEMINATED TO OTHERS WITHOUT THE WRITTEN PERMISSION OF AMPEX CORPORATION.	<small>UNLESS OTHERWISE SPECIFIED</small> DIMENSIONS ARE IN INCHES AND FRACTIONS UNLESS OTHERWISE SPECIFIED. DIMENSIONS ARE TO BE TAKEN TO THE CENTER OF HOLES UNLESS OTHERWISE SPECIFIED. DIMENSIONS ARE TO BE TAKEN TO THE CENTER OF HOLES UNLESS OTHERWISE SPECIFIED. DIMENSIONS ARE TO BE TAKEN TO THE CENTER OF HOLES UNLESS OTHERWISE SPECIFIED.	<small>SIGNATURE</small> DATE	<small>DATE</small> DRAWN BY CHECKED BY APPROVED BY	AMPEX <small>COMPLETE THE FOLLOWING INFORMATION</small> Part No. 5203516
				SCHEMATIC READ ELECTRONICS P/E
<small>SCALE</small> D 09150		<small>SCALE</small> 5203516		<small>SCALE</small> 5203516

REVISONS				
LR	ZONE	DESCRIPTION	SIGNATURE AND DATE	
P			DFTG	CHK
		ECN N 2507		
		ECN N 2648-2		
		ECN N 2717-2		

COMMUN
-99

P/N	DESCRIPTION
013-188	CR11
013-983	VR1
014-247	Q4
014-248	Q3
5299999-415	Q101,102,104 THRU 901,902,904
586-797	U1 THRU U5
586-109	U6
586-581	U7,18
586-075	U8,10,12,14,16
587-249	U9,11,13,15,17
586-784	U19,20,21
586-756	U22
586-478	U101 THRU 901
586-549	U102 THRU 902
059-274	R51
5299997-102	R11,13,15,17,19,21,23,25,27,29,31,101,102,105,106 THRU 901,902,905,906,30,118 THRU 918,125 THRU 925
-103	R110 THRU 910
-104	R12,14,16,18,20,22,24,26,28
-123	R47
-182	R45,46,108,109,112,117 THRU 908,909,912,917
-220	R49
5299997-271	R50

P/N	DESCRIPTION
5299997-273	R1 THRU R9
-183	R123 THRU 923
-512	R32 THRU 103,104,120 THRU 903,904,920
-202	R121 THRU 921
5299997-752	R119,122 THRU 919,922
5299998-391	R48
5299999-429	R52
5299997-222	R124 THRU 924
034-213	C11
5299999-250	C13,23,110,112,116 THRU 910,912,916
-347	C15 THRU C20,24,105,113,115,118,119 THRU 905,913,915,918,919
-387	C102,103,108,114 THRU 902,903,908,914
5299999-367	C10
037-985	C12,14,21,22
614-762	JP11,101 THRU 901
173-012	CH1 THRU CH9, TP1 THRU TP3, TP,GRD,+5V

DESCRIPT.	PART NUMBER											
	45 IPS		45-50IPS		37.5IPS		25 IPS		12.5 IPS		18.75IPS	
	-01	-05	-11	-15	-21	-25	-31	-41				
R107THRU907	5299997-101	5299997-101	5299997-101	5299997-101	5299997-820	5299997-820	5299997-151	5299997-121				
R10	5299997-183	5299997-183	5299997-273	5299997-273	5299997-393	5299997-393	5299997-393	5299997-473				
R113 THRU 913	5299997-202	5299997-202	5299997-202	5299997-202	5299997-202	5299997-202	5299997-202	5299997-202				
R115 THRU 915	5299997-223	5299997-223	5299997-273	5299997-273	5299997-273	5299997-273	5299997-223	5299997-333				
R116 THRU 916	5299997-223	5299997-133	5299997-273	5299997-273	5299997-273	5299997-273	5299997-183	5299997-223	5299997-333			
R114 THRU 914	5299997-273	5299997-273	5299997-223	5299997-223	5299997-223	5299997-223	5299997-723	5299997-223	5299997-223			
C101 THRU 901	034-240	034-240	034-199	034-199	034-289	034-289	034-288	034-930	056-292			
C109 THRU 909	034-931	034-931	034-288	034-288	034-283	034-283	034-970	034-970				
C104 THRU 904	5299999-347	5299999-372	5299999-347	5299999-347	5299999-347	5299999-347	5299999-347	5299999-347	5299999-347			
C1 THRU C9	5299999-362	5299999-362	5299999-363	5299999-363	5299999-349	5299999-349	5299999-364	5299999-372				
C107 THRU 907	034-962	034-962	034-181	034-181	034-940	034-940	034-228	034-938				
C106 THRU 906	614-762	614-762	614-762	614-762	614-762	614-762	614-762	614-762				
C111 THRU 911	034-962	034-962	034-181	034-181	034-940	034-940	034-177	034-938				
R41	OPEN	OPEN	OPEN	OPEN	OPEN	OPEN	OPEN	OPEN				
R42	OPEN	OPEN	OPEN	OPEN	OPEN	OPEN	OPEN	OPEN				
R43	OPEN	OPEN	OPEN	OPEN	OPEN	OPEN	OPEN	OPEN				
R44	OPEN	OPEN	OPEN	OPEN	OPEN	OPEN	OPEN	OPEN				
R53	OPEN	OPEN	OPEN	OPEN	OPEN	OPEN	OPEN	OPEN				
R111 THRU 911	OPEN	OPEN	OPEN	OPEN	OPEN	OPEN	OPEN	OPEN				
CR12	OPEN	OPEN	OPEN	OPEN	OPEN	OPEN	OPEN	OPEN				
Q1	OPEN	OPEN	OPEN	OPEN	OPEN	OPEN	OPEN	OPEN				
Q2	OPEN	OPEN	OPEN	OPEN	OPEN	OPEN	OPEN	OPEN				
Q103 THRU 903	OPEN	OPEN	OPEN	OPEN	OPEN	OPEN	OPEN	OPEN				

- FOR -31 ONLY.
 - R114 THRU R116 (P/N 5299997-223) BECOME C109 THRU C107 (P/N 034-970); C108 THRU C106 (P/N 034-970) BECOME R114 THRU R116 (P/N 5299997-223).
 - ALL COMPONENT IN DOTTED LINES ARE OPEN.
 - ALL JUMPERS TO BE 614-762.
 - MARK DASH NUMBER AND ISSUE LETTER WITH WHITE INK PER B01-1.
 - PLUS SIGN ON CAPACITOR INDICATES POSITIVE.
 - HEAVY LINE ON DIODE INDICATES CATHODE.
 - 4 FOR SCHEMATIC SEE 5203516.
 - 3 FOR B/M SEE 5203515.
 - 2 ASSEMBLE PER AMPEX STD HC2-2.
 - 1 FOR ALL COMPONENTS SEE TABLE.
- NOTED UNLESS OTHERWISE SPECIFIED

NOT USED	JP12 3,5,6,9,9,10
OPEN	CR1 THRU 901
OPEN	C10 THRU 900

<p>UNLESS OTHERWISE SPECIFIED</p> <p>ALL DIMENSIONS ARE IN INCHES AND DECIMALS THEREOF UNLESS OTHERWISE SPECIFIED</p> <p>ALL DIMENSIONS ARE TO CENTER UNLESS OTHERWISE SPECIFIED</p> <p>ALL DIMENSIONS ARE TO CENTER UNLESS OTHERWISE SPECIFIED</p> <p>ALL DIMENSIONS ARE TO CENTER UNLESS OTHERWISE SPECIFIED</p>	<p>DATE</p> <p>DRAWN BY</p> <p>CHK BY</p> <p>DFTG</p> <p>AVDD</p> <p>AVDD</p> <p>AUTH</p>	<p>AMPEX</p> <p>COMPUTER PRODUCTS DIVISION</p> <p>San Jose, California 95051</p>
<p>5203515 TM 100</p>	<p>PCBA READ</p> <p>ELECTRONICS P/E</p>	<p>SIZE CODE:CENT NO</p> <p>D 09150 5203517</p>

REVISIONS				
LTR	ZONE	DESCRIPTION	SIGNATURE AND DATE	
			DFTG	ENGRG
A		PRD TO		
B		N2661		
C		N2695-3		
D		N2820-4		

P/N	REF DESIGNATIONS	P/N	REF DESIGNATIONS
013-257	VR2	5299997-102	R11,13,17,22,23,28,32,101 THRU 901, 102 THRU 902
581-157	CR1,2,3,6,101 THRU 901,102 THRU 902,103 THRU 903	-123	R12
013-678	CR4,5,14	-152	R 15
013-696	CR7	-182	R14
013-983	VR1	-221	R4, 6
014-247	Q4	-222	R1, 2
014-597	O2	-241	R18, 19
10 030-945	JP 4 OR R39	-271	R3, 5
034-177	C14	-331	R9, 25, 31
034-288	C2	-332	R20, 33,
037-990	C1	-393	R29
041-486	C9,10,16	-470	R10
041-671	R27, R36	-471	R30
058-753	R26	-562	R24
173-012	R105 THRU 905	5299997-922	R8, 38
580-465	TP1 THRU TP5	034-328	C102 THRU 902
586-124	O1	5299999-256	Q5
586-269	U2	-257	Q3, 6
586-533	U1		
586-756	U4, 7,10,13,16,19,22,25,28,34.	-250	C6, 7, 8, 11,13, 17 THRU 30
586-759	U3	-362	C3, 4
586-871	U40	-364	C5
586-890	U44	5299999-347	C15
587-510	U43	014-581	Q101 THRU 901, 102 THRU 902
587-533	U5, 8,11,14,17,20,23,26,29,35,42.	5299999-416	R103 THRU 903, 104 THRU 904
587-534	U21, 33, 37	5299997-511	R37
587-750	U9, 27, 31	5299999-338	W1 (BUS BAR)
589-042	U38	013-934	VR4
587-947	U6, 12, 15, 24, 30, 36	058-844	R16
	U18, 32, 39, 41 (SN74LS14)	5299998-332	R7

VERSION TABLE 10 11

	ASSY P/N	JP4 or R39
TM 100-TME	5204750-01	615-012 & 600-237
TM 100 11	5204750-02	5299999-429

- 11 FOR 5204750-02 ONLY: APPLY F.E.B. N 119.
- 10 SEE VERSION TABLE.
- 9. ASSY P/N TO BE AS PER VERSION TABLE.
- 8. FOR SCHEMATIC SEE 5204751
- 7. JP1,2,3,5 ARE ON SOC 6.
- 6 MARK PART NO. AND ISSUE LTR WITH WHITE INK PER 3124500, PARA 3.1.
- 5. TRIMPOTS NOT TO SUBMERGED IN WATER.
- 4. HEAVY LINE ON DIODE INDICATES CATHODE.
- 3. PLUS SIGN ON CAPACITORS INDICATES POSITIVE.
- 2. COMPONENT DESIGNATIONS ARE FOR REFERENCE ONLY.
- 1. ASSEMBLE PER AMPEX STDS.

NOTES: UNLESS OTHERWISE SPECIFIED

NOTICE		UNLESS OTHERWISE SPECIFIED		SIGNATURE		DATE		PARTS LIST <input checked="" type="checkbox"/>	
THIS DRAWING SHALL NOT BE OPEN FILED, USED FOR ANY PURPOSE OTHER THAN THAT FOR WHICH PROVIDED OR DISCLOSED, IN WHOLE OR IN PART, WITHOUT THE WRITTEN CONSENT OF AMPEX CORPORATION PROVIDED, HOWEVER, THAT IF THIS DRAWING IS DISCLOSED TO BE DEEMED TO THE GOVERNMENT, OR TO A GOVERNMENT CONTRACTOR, PURSUANT TO A GOVERNMENT PRIME OR SUBCONTRACT, THE GOVERNMENT MAY MAKE SUCH USE OF THIS DRAWING AS IS AUTHORIZED BY THE GOVERNMENT CONTRACTOR.		DIMENSIONS ARE IN INCHES AND INCLUDE CHEMICALLY APPLIED OR PLATED FINISHES		DRAWN BY <i>McCham</i>		2/4-77		AMPEX COMPUTER PRODUCTS DIVISION Marina del Rey, California 90291	
TOL +		2 PL 3 PL 1 IN LH		CHK BY				PCBA - WRITE ELECTRONICS PE/NRZ TM100-TME	
REMOVE BURRS AND SHARP EDGES DRILL TOL PER AND 10337		MATERIAL		DFTG				SIZE	
FINISH				APPROV				OCCE IDENT NO.	
								D 09150 5204752	
								SCALE	
								DO NOT SCALE THIS PRINT	
								SHEET 1 OF 1	

VERSION TABLE

B IERN N 2319
C IECN N 2107
D IECN N 2148

MODEL & SPEED	FUNCTION DESCRIPTION	ASSY PART NO.	REF. DWG.	PART																									
				A	B	C	D	E	F	G	H	J	K	L	M	N	P	R	S	T	U	V	W	X	Y	Z	AA	BB	
TME UP TO 50 IPS WITH TXFMR 5203488-01 "OR" 5204830-01	W. SEL. SW. / W. OVERVLT. PROTECT.	5204575-01	5204577	USED	USED	USED	NONE	NONE	119-234	USED	2N 4442	330n, 1/4W, 2%	1N 751A, CD 32	1N 4446	43000uF, 25V, 470n, 2W, 5%	MR 751	43000uF, 25V, 470n, 2W, 5%	470n, 2W, 5%	YES	YES	22000uF, 25V	MR 751	470n, 2W, 5%	MR 751	15uF, 20V, 10%	48000uF, 40V			
	W/O F 1000	-02		NOT USED	NOT USED	NOT USED	NONE	NONE	JP 4	NOT USED	NONE	NONE	NONE	NONE											NONE				
	W. F 1000 SEL. SW.	-03		USED	USED	USED	NONE	NONE	119-234	USED	NONE	NONE	NONE	NONE											NONE				
	W/O F 1000 D. CH.	-04		NOT USED	NOT USED	NOT USED	SN 7438 N	5.1Kn, 1/4W, 2%	119-234	NOT USED	NONE	NONE	NONE	NONE												NONE			
TM 100+ TXFMR 5204746-01	W. F 1000 / W. OVERVLT. PROTECT.	520480-01	520482	USED	USED	USED	NONE	NONE	JP 4	USED	2N 4442	330n, 1/4W, 2%	1N 751A, CD 32	1N 4446	43000uF, 25V, 470n, 2W, 5%	MR 751	43000uF, 25V, 470n, 2W, 5%	470n, 2W, 5%	YES	YES	22000uF, 25V	MR 751	470n, 2W, 5%	MR 751	15uF, 20V, 10%	48000uF, 40V			
	W/O F 1000	-02		NOT USED	NOT USED	NOT USED	NONE	NONE	JP 4	NOT USED	NONE	NONE	NONE	NONE											NONE				
	WF 1000 & SELECT SWITCH	-03		USED	USED	USED	NONE	NONE	119-234	USED	NONE	NONE	NONE	NONE											NONE				
	W/O F 1000 FULL DAISY CHAIN	-04		NOT USED	NOT USED	NOT USED	SN 7438 N	5.1Kn, 1/4W, 2%	119-234	NOT USED	NONE	NONE	NONE	NONE												NONE			
TME LO/HI SPEED TXFMR 5204831-01	W. SEL. SW. / W. OVERVLT. PROTECT.	5204875-01	5204877	USED	USED	USED	NONE	NONE	119-234	USED	2N 4442	330n, 1/4W, 2%	1N 751A, CD 32	1N 4446	43000uF, 25V, 470n, 2W, 5%	MR 751	43000uF, 25V, 470n, 2W, 5%	470n, 2W, 5%	YES	YES	22000uF, 25V	MR 751	470n, 2W, 5%	MR 751	15uF, 20V, 10%	48000uF, 40V			
	W/O F 1000	-02		NOT USED	NOT USED	NOT USED	NONE	NONE	JP 4	NOT USED	NONE	NONE	NONE	NONE											NONE				
	WF 1000 SEL. SW.	-03		USED	USED	USED	NONE	NONE	119-234	USED	NONE	NONE	NONE	NONE											NONE				
	W/O F 1000 D. CH.	-04		NOT USED	NOT USED	NOT USED	SN 7438 N	5.1Kn, 1/4W, 2%	119-234	NOT USED	NONE	NONE	NONE	NONE												NONE			

LAST USED	NOT USED	DELETE	DESIGN.	CMPT. REF.
U2			PART D	U1
C6			E	R5
R11			F	S1 OR PL
SCR 1			G	SCR 1
U1 2			H	R 11
VR 1			I	R 1
JP 3			J	CR 1 - P20
TB 2			K	2
P30	P2, 35, 75, 11, 14, 17		L	22
J34	J11, P1, P13, 14, 15		M	2, 3, 4
S7			N	CT
BB			O	R1
PART 35			P	25

ASSY PART NO.	JUMPER						
	a to b	h to z	m to n	x to y	bb to cc	dd to ee	JP
5204575-01 THRU -08	YES	YES	YES	YES	YES	YES	NO
520480-01 THRU -08	YES	YES	YES	YES	YES	YES	NO
5204875-01 THRU -08	YES	YES	YES	YES	YES	YES	NO

1. PART AA-01
2. PART BB-01
3. PART CC-01
4. PART DD-01
5. PART EE-01
6. PART FF-01
7. PART GG-01
8. PART HH-01
9. PART II-01
10. PART JJ-01
11. PART KK-01
12. PART LL-01
13. PART MM-01
14. PART NN-01
15. PART OO-01
16. PART PP-01
17. PART QQ-01
18. PART RR-01
19. PART SS-01
20. PART TT-01
21. PART UU-01
22. PART VV-01
23. PART WW-01
24. PART XX-01
25. PART YY-01
26. PART ZZ-01
27. PART AA-02
28. PART BB-02
29. PART CC-02
30. PART DD-02
31. PART EE-02
32. PART FF-02
33. PART GG-02
34. PART HH-02
35. PART II-02
36. PART JJ-02
37. PART KK-02
38. PART LL-02
39. PART MM-02
40. PART NN-02
41. PART OO-02
42. PART PP-02
43. PART QQ-02
44. PART RR-02
45. PART SS-02
46. PART TT-02
47. PART UU-02
48. PART VV-02
49. PART WW-02
50. PART XX-02
51. PART YY-02
52. PART ZZ-02
53. PART AA-03
54. PART BB-03
55. PART CC-03
56. PART DD-03
57. PART EE-03
58. PART FF-03
59. PART GG-03
60. PART HH-03
61. PART II-03
62. PART JJ-03
63. PART KK-03
64. PART LL-03
65. PART MM-03
66. PART NN-03
67. PART OO-03
68. PART PP-03
69. PART QQ-03
70. PART RR-03
71. PART SS-03
72. PART TT-03
73. PART UU-03
74. PART VV-03
75. PART WW-03
76. PART XX-03
77. PART YY-03
78. PART ZZ-03
79. PART AA-04
80. PART BB-04
81. PART CC-04
82. PART DD-04
83. PART EE-04
84. PART FF-04
85. PART GG-04
86. PART HH-04
87. PART II-04
88. PART JJ-04
89. PART KK-04
90. PART LL-04
91. PART MM-04
92. PART NN-04
93. PART OO-04
94. PART PP-04
95. PART QQ-04
96. PART RR-04
97. PART SS-04
98. PART TT-04
99. PART UU-04
100. PART VV-04
101. PART WW-04
102. PART XX-04
103. PART YY-04
104. PART ZZ-04
105. PART AA-05
106. PART BB-05
107. PART CC-05
108. PART DD-05
109. PART EE-05
110. PART FF-05
111. PART GG-05
112. PART HH-05
113. PART II-05
114. PART JJ-05
115. PART KK-05
116. PART LL-05
117. PART MM-05
118. PART NN-05
119. PART OO-05
120. PART PP-05
121. PART QQ-05
122. PART RR-05
123. PART SS-05
124. PART TT-05
125. PART UU-05
126. PART VV-05
127. PART WW-05
128. PART XX-05
129. PART YY-05
130. PART ZZ-05
131. PART AA-06
132. PART BB-06
133. PART CC-06
134. PART DD-06
135. PART EE-06
136. PART FF-06
137. PART GG-06
138. PART HH-06
139. PART II-06
140. PART JJ-06
141. PART KK-06
142. PART LL-06
143. PART MM-06
144. PART NN-06
145. PART OO-06
146. PART PP-06
147. PART QQ-06
148. PART RR-06
149. PART SS-06
150. PART TT-06
151. PART UU-06
152. PART VV-06
153. PART WW-06
154. PART XX-06
155. PART YY-06
156. PART ZZ-06
157. PART AA-07
158. PART BB-07
159. PART CC-07
160. PART DD-07
161. PART EE-07
162. PART FF-07
163. PART GG-07
164. PART HH-07
165. PART II-07
166. PART JJ-07
167. PART KK-07
168. PART LL-07
169. PART MM-07
170. PART NN-07
171. PART OO-07
172. PART PP-07
173. PART QQ-07
174. PART RR-07
175. PART SS-07
176. PART TT-07
177. PART UU-07
178. PART VV-07
179. PART WW-07
180. PART XX-07
181. PART YY-07
182. PART ZZ-07
183. PART AA-08
184. PART BB-08
185. PART CC-08
186. PART DD-08
187. PART EE-08
188. PART FF-08
189. PART GG-08
190. PART HH-08
191. PART II-08
192. PART JJ-08
193. PART KK-08
194. PART LL-08
195. PART MM-08
196. PART NN-08
197. PART OO-08
198. PART PP-08
199. PART QQ-08
200. PART RR-08
201. PART SS-08
202. PART TT-08
203. PART UU-08
204. PART VV-08
205. PART WW-08
206. PART XX-08
207. PART YY-08
208. PART ZZ-08
209. PART AA-09
210. PART BB-09
211. PART CC-09
212. PART DD-09
213. PART EE-09
214. PART FF-09
215. PART GG-09
216. PART HH-09
217. PART II-09
218. PART JJ-09
219. PART KK-09
220. PART LL-09
221. PART MM-09
222. PART NN-09
223. PART OO-09
224. PART PP-09
225. PART QQ-09
226. PART RR-09
227. PART SS-09
228. PART TT-09
229. PART UU-09
230. PART VV-09
231. PART WW-09
232. PART XX-09
233. PART YY-09
234. PART ZZ-09
235. PART AA-10
236. PART BB-10
237. PART CC-10
238. PART DD-10
239. PART EE-10
240. PART FF-10
241. PART GG-10
242. PART HH-10
243. PART II-10
244. PART JJ-10
245. PART KK-10
246. PART LL-10
247. PART MM-10
248. PART NN-10
249. PART OO-10
250. PART PP-10
251. PART QQ-10
252. PART RR-10
253. PART SS-10
254. PART TT-10
255. PART UU-10
256. PART VV-10
257. PART WW-10
258. PART XX-10
259. PART YY-10
260. PART ZZ-10
261. PART AA-11
262. PART BB-11
263. PART CC-11
264. PART DD-11
265. PART EE-11
266. PART FF-11
267. PART GG-11
268. PART HH-11
269. PART II-11
270. PART JJ-11
271. PART KK-11
272. PART LL-11
273. PART MM-11
274. PART NN-11
275. PART OO-11
276. PART PP-11
277. PART QQ-11
278. PART RR-11
279. PART SS-11
280. PART TT-11
281. PART UU-11
282. PART VV-11
283. PART WW-11
284. PART XX-11
285. PART YY-11
286. PART ZZ-11
287. PART AA-12
288. PART BB-12
289. PART CC-12
290. PART DD-12
291. PART EE-12
292. PART FF-12
293. PART GG-12
294. PART HH-12
295. PART II-12
296. PART JJ-12
297. PART KK-12
298. PART LL-12
299. PART MM-12
300. PART NN-12
301. PART OO-12
302. PART PP-12
303. PART QQ-12
304. PART RR-12
305. PART SS-12
306. PART TT-12
307. PART UU-12
308. PART VV-12
309. PART WW-12
310. PART XX-12
311. PART YY-12
312. PART ZZ-12
313. PART AA-13
314. PART BB-13
315. PART CC-13
316. PART DD-13
317. PART EE-13
318. PART FF-13
319. PART GG-13
320. PART HH-13
321. PART II-13
322. PART JJ-13
323. PART KK-13
324. PART LL-13
325. PART MM-13
326. PART NN-13
327. PART OO-13
328. PART PP-13
329. PART QQ-13
330. PART RR-13
331. PART SS-13
332. PART TT-13
333. PART UU-13
334. PART VV-13
335. PART WW-13
336. PART XX-13
337. PART YY-13
338. PART ZZ-13
339. PART AA-14
340. PART BB-14
341. PART CC-14
342. PART DD-14
343. PART EE-14
344. PART FF-14
345. PART GG-14
346. PART HH-14
347. PART II-14
348. PART JJ-14
349. PART KK-14
350. PART LL-14
351. PART MM-14
352. PART NN-14
353. PART OO-14
354. PART PP-14
355. PART QQ-14
356. PART RR-14
357. PART SS-14
358. PART TT-14
359. PART UU-14
360. PART VV-14
361. PART WW-14
362. PART XX-14
363. PART YY-14
364. PART ZZ-14
365. PART AA-15
366. PART BB-15
367. PART CC-15
368. PART DD-15
369. PART EE-15
370. PART FF-15
371. PART GG-15
372. PART HH-15
373. PART II-15
374. PART JJ-15
375. PART KK-15
376. PART LL-15
377. PART MM-15
378. PART NN-15
379. PART OO-15
380. PART PP-15
381. PART QQ-15
382. PART RR-15
383. PART SS-15
384. PART TT-15
385. PART UU-15
386. PART VV-15
387. PART WW-15
388. PART XX-15
389. PART YY-15
390. PART ZZ-15
391. PART AA-16
392. PART BB-16
393. PART CC-16
394. PART DD-16
395. PART EE-16
396. PART FF-16
397. PART GG-16
398. PART HH-16
399. PART II-16
400. PART JJ-16
401. PART KK-16
402. PART LL-16
403. PART MM-16
404. PART NN-16
405. PART OO-16
406. PART PP-16
407. PART QQ-16
408. PART RR-16
409. PART SS-16
410. PART TT-16
411. PART UU-16
412. PART VV-16
413. PART WW-16
414. PART XX-16
415. PART YY-16
416. PART ZZ-16
417. PART AA-17
418. PART BB-17
419. PART CC-17
420. PART DD-17
421. PART EE-17
422. PART FF-17
423. PART GG-17
424. PART HH-17
425. PART II-17
426. PART JJ-17
427. PART KK-17
428. PART LL-17
429. PART MM-17
430. PART NN-17
431. PART OO-17
432. PART PP-17
433. PART QQ-17
434. PART RR-17
435. PART SS-17
436. PART TT-17
437. PART UU-17
438. PART VV-17
439. PART WW-17
440. PART XX-17
441. PART YY-17
442. PART ZZ-17
443. PART AA-18
444. PART BB-18
445. PART CC-18
446. PART DD-18
447. PART EE-18
448. PART FF-18
449. PART GG-18
450. PART HH-18
451. PART II-18
452. PART JJ-18
453. PART KK-18
454. PART LL-18
455. PART MM-18
456. PART NN-18
457. PART OO-18
458. PART PP-18
459. PART QQ-18
460. PART RR-18
461. PART SS-18
462. PART TT-18
463. PART UU-18
464. PART VV-18
465. PART WW-18
466. PART XX-18
467. PART YY-18
468. PART ZZ-18
469. PART AA-19
470. PART BB-19
471. PART CC-19
472. PART DD-19
473. PART EE-19
474. PART FF-19
475. PART GG-19
476. PART HH-19
477. PART II-19
478. PART JJ-19
479. PART KK-19
480. PART LL-19
481. PART MM-19
482. PART NN-19
483. PART OO-19
484. PART PP-19
485. PART QQ-19
486. PART RR-19
487. PART SS-19
488. PART TT-19
489. PART UU-19
490. PART VV-19
491. PART WW-19
492. PART XX-19
493. PART YY-19
494. PART ZZ-19
495. PART AA-20
496. PART BB-20
497. PART CC-20
498. PART DD-20
499. PART EE-20
500. PART FF-20
501. PART GG-20
502. PART HH-20
503. PART II-20
504. PART JJ-20
505. PART KK-20
506. PART LL-20
507. PART MM-20
508. PART NN-20
509. PART OO-20
510. PART PP-20
511. PART QQ-20
512. PART RR-20
513. PART SS-20
514. PART TT-20
515. PART UU-20
516. PART VV-20
517. PART WW-20
518. PART XX-20
519. PART YY-20
520. PART ZZ-20
521. PART AA-21
522. PART BB-21
523. PART CC-21
524. PART DD-21
525. PART EE-21
526. PART FF-21
527. PART GG-21
528. PART HH-21
529. PART II-21
530. PART JJ-21
531. PART KK-21
532. PART LL-21
533. PART MM-21
534. PART NN-21
535. PART OO-21
536. PART PP-21
537. PART QQ-21
538. PART RR-21
539. PART SS-21
540. PART TT-21
541. PART UU-21
542. PART VV-21
543. PART WW-21
544. PART XX-21
545. PART YY-21
546. PART ZZ-21
547. PART AA-22
548. PART BB-22
549. PART CC-22
550. PART DD-22
551. PART EE-22
552. PART FF-22
553. PART GG-22
554. PART HH-22
555. PART II-22
556. PART JJ-22
557. PART KK-22
558. PART LL-22
559. PART MM-22
560. PART NN-22
561. PART OO-22
562. PART PP-22
563. PART QQ-22
564. PART RR-22
565. PART SS-22
566. PART TT-22
567. PART UU-22
568. PART VV-22
569. PART WW-22
570. PART XX-22
571. PART YY-22
572. PART ZZ-22
573. PART AA-23
574. PART BB-23
575. PART CC-23
576. PART DD-23
577. PART EE-23
578. PART FF-23
579. PART GG-23
580. PART HH-23
581. PART II-23
582. PART JJ-23
583. PART KK-23
584. PART LL-23
585. PART MM-23
586. PART NN-23
587. PART OO-23
588. PART PP-23
589. PART QQ-23
590. PART RR-23
591. PART SS-23
592. PART TT-23
593. PART UU-23
594. PART VV-23
595. PART WW-23
596. PART XX-23
597. PART YY-23
598. PART ZZ-23
599. PART AA-24
600. PART BB-24
601. PART CC-24
602. PART DD-24
603. PART EE-24
604. PART FF-24
605. PART GG-24
606. PART HH-24
607. PART II-24
608. PART JJ-24
609. PART KK-24
610. PART LL-24
611. PART MM-24
612. PART NN-24
613. PART OO-24
614. PART PP-24
615. PART QQ-24
616. PART RR-24
617. PART SS-24
618. PART TT-24
619. PART UU-24
620. PART VV-24
621. PART WW-24
622. PART XX-24
623. PART YY-24
624. PART ZZ-24
625. PART AA-25
626. PART BB-25
627. PART CC-25
628. PART DD-25
629. PART EE-25
630. PART FF-25
631. PART GG-25
632. PART HH-25
633. PART II-25
634. PART JJ-25
635. PART KK-25
636. PART LL-25
637. PART MM-25
638. PART NN-25
639. PART OO-25
640. PART PP-25
641. PART QQ-25
642. PART RR-25
643. PART SS-25
644. PART TT-25
645. PART UU-25
646. PART VV-25
647. PART WW-25
648. PART XX-25
649. PART YY-25
650. PART ZZ-25
651. PART AA-26
652. PART BB-26
653. PART CC-26
654. PART DD-26
655. PART EE-26
656. PART FF-26
657. PART GG-26
658. PART HH-26
659. PART II-26
660. PART JJ-26
661. PART KK-26
662. PART LL-26
663. PART MM-26
664. PART NN-26
665. PART OO-26
666. PART PP-26
667. PART QQ-26
668. PART RR-26
669. PART SS-26
670. PART TT-26
671. PART UU-26
672. PART VV-26
673. PART WW-26
674. PART XX-26
675. PART YY-26
676. PART ZZ-26
677. PART AA-27
678. PART BB-27
679. PART CC-27
680. PART DD-27
681. PART EE-27
682. PART FF-27
683. PART GG-27
684. PART HH-27
685. PART II-27
686. PART JJ-27
687. PART KK-27
688. PART LL-27
689. PART MM-27
690. PART NN-27
691. PART OO-27
692. PART PP-27
693. PART QQ-27
694. PART RR-27
695. PART SS-27
696. PART TT-27
697. PART UU-27
698. PART VV-27
699. PART WW-27
700. PART XX-27
701. PART YY-27
702. PART ZZ-27
703. PART AA-28
704. PART BB-28
705. PART CC-28
706. PART DD-28
707. PART EE-28
708. PART FF-28
709. PART GG-28
710. PART HH-28
711. PART II-28
712. PART JJ-28
713. PART KK-28
714. PART LL-28
715. PART MM-28
716. PART NN-28
717. PART OO-28
718. PART PP-28
719. PART QQ-28
720. PART RR-28
721. PART SS-28
722. PART TT-28
723. PART UU-28
724. PART VV-28
725. PART WW-28
726. PART XX-28
727. PART YY-28
728. PART ZZ-28
729. PART AA-29
730. PART BB-29
731. PART CC-29
732. PART DD-29
733. PART EE-29
734. PART FF-29
735. PART GG-29
736. PART HH-29
737. PART II-29
738. PART JJ-29
739. PART KK-29
740. PART LL-29
741. PART MM-29
742. PART NN-29
743. PART OO-29
744. PART PP-29
745. PART QQ-29
746. PART RR-29
747. PART SS-29
748. PART TT-29
749. PART UU-29
750. PART VV-29
751. PART WW-29
752. PART XX-29
753. PART YY-29
754. PART ZZ-29
755. PART AA-30
756. PART BB-30
757. PART CC-30
758. PART DD

